

C & C ASSOCIATES

troubleshooting

guides

ELECTRONIC TROUBLESHOOTING THE OLYMPUS OM-4

1. CIRCUIT DESCRIPTION

Power Circuit

As with other OM-series cameras, battery positive connects to the chassis and to the flex circuit through screws holding the circuit in place. In this guide, battery positive is designated as **Vcc** and connections to the chassis are shown as the "earth" symbol.

A black wire connects battery negative to the **Shutter Terminal Board** and to the main flex near the rows of variable resistors. From there, conductors fan out to pins 22, 51, **IC-101**; pins 6, 26, 62, **IC-102**; and pin 13, **IC-103**.

The **Display Flex** and **Reset Board** receive battery negative through a black wire soldered to the **Main Flex** near **IC-101**.

When batteries are installed, a quartz oscillator involving two capacitors and **IC-101** is activated. Pressing the release button one-half stroke closes switch **SW-111** to connect pins 15 and 18, **IC-101**. **IC-101** then signals **IC-102** to power up the metering circuit and the **LCD** for about 2 minutes. Power signals are from pins 53, 54, **IC-101** to pins 24, 23, **IC-102**. Pressing the release button renews the 2-minute power latch. A 1.8v constant voltage, **Vref**, is generated at pin 75, **IC-102**.

A diode is connected to the battery terminals in reverse direction to protect the circuit if batteries are installed backward.

Battery requirement: two S-76 silver oxide or two LR44 alkaline-manganese.

Metering Circuit

There are four ICs involved in metering, exposure control, and display. **IC-101** contains a microprocessor (CPU) and understands only binary signals as inputs and outputs. It keeps track of mode, calculates exposures, and owns the clock. **IC-102** is a bipolar IC which contains comparators for A/D conversion, watches over variable resistors, controls magnets and LEDs, and communicates with **IC-101**.

IC-103, under the floor panel of the mirror box, supports "average" and "spot" photodiodes with amplifiers and temperature compensation circuits. It also takes care of integration for automatic exposure in ambient and flash modes. **IC-104** is a decoder/driver for the comprehensive **LCD**.

Prior to exposure a sub-mirror behind the reflex mirror reflects a portion of light going to the viewfinder to the photodiodes on **IC-103**. A BV voltage, changing 18mv/Ev with light, is output from pin 16, **IC-103** to pin

7, **IC-102**. At the same time, **IC-102** watches aperture setting (**AV-VR** at pin 74), ASA (**SV-VR** at pin 67), and shutter speed setting (**TV-VR** at pin 73). Although variable resistors are used, they are part of an analog-to-digital conversion process which changes all exposure information to binary codes for the CPU.

The code is sent back as series data from pin 38, **IC-102** to pin 29, **IC-101** so the CPU knows ASA, aperture setting, and shutter speed setting. How the CPU interprets the data depends upon operating mode selected. **IC-101** will calculate an exposure, then send a coded message to **IC-104** which drives an **LCD** display to indicate exposure and other information. A quartz clock operating at 32.8 KHz keeps the operation orderly and the whole process is repeated every 100ms to keep data up to date.

IC-101 sends digital-to-analog data along eight lines (DAC-0 to DAC-7). During exposure in Manual and Spot modes, **IC-103** will need analog voltage to set exposure times.

Details such as different voltage levels between average and spot SPDs are taken care of by voltage boosting circuits. Because of a wide exposure range, integration capacitors are switched in and out of circuit according to ASA setting.

Release Circuit

Pressing the release button full stroke mechanically unlatches the mirror as with other OM-series cameras. As the mirror rises, switch **SW-101** closes to connect **Vcc (B+)** through two diodes to bases of transistors **Q-103** and **Q-904**. As the transistors turn on, pin 49, **IC-101** is set low and pin 58, **IC-102** is set high. In this manner the ICs are told the mirror is on its way up and they had better get ready for an exposure. **IC-101** stores exposure data and LEDs are temporarily disabled to conserve power. **IC-101** also sets an exposure program according to mode.

IC-102 tests battery voltage to be sure it is above 2.65v, then pin 61 goes low. Pin 61 is connected to the base of transistor **Q-201** (PNP) on the shutter board. **Q-201** switches on causing capacitor **C-201** to discharge through the coil of combination magnet **M-1**. **M-1** repels its keeper which unlatches the opening curtain. **IC-102** then waits for switch **SW-103**, the **Trigger Switch (Timing Switch)**, to signal the first curtain is moving before initiating exposure control.

If battery voltage is below 2.65v or there are no batteries, **IC-102** does not release the opening curtain. For low voltage lockout situations, there is a **Reset Circuit** which resets the **CPU** when voltage goes above 2.90v or new batteries are installed. This feature eliminates the manual reset function necessary on OM-2 models. **IC-102** will wait to see if voltage rises to 2.90v. If it does, the release cycle continues.

Setting the speed ring to mechanical "60" or "B" overrides **IC-102's** control so the shutter is released by the mirror.

Exposure Control

Here is a list of exposure modes, all of which are aperture priority or manual.

1. Automatic by average light measurement. This is essentially the same off-the-film method as used by OM-2 and OM-10.
2. Automatic by spot measurement. Unlike the OM-2, exposure is calculated in advance.
3. Automatic by memory, wherein an exposure is repeated on all subsequent exposures for up to an hour.
4. Manual by average light measurement, which is similar to match needle only with an LCD bar graph instead of a needle.
5. Manual by spot light measurement.
6. Any mode using spot measurement can be with highlight or shadow compensation.
7. Off-the-film flash exposure control.

Where and how all of these options are used is the operator's province. Ours is to know how each mode functions from an electrical standpoint.

1. Automatic by Average Light

ASA is the only exposure component needed in advance for this exposure mode. Subject brightness and aperture are still measured prior to exposure, but are only used for display purposes.

As the mirror rises and the ICs prepare for exposure, voltage to one input of comparator **CP-M** inside **IC-102** is set to a value based upon ASA. The second input is connected to the integration output from pin 10, **IC-103**. Because **IC-102** has not signaled **IC-103** to start integration, voltage at the second input is set low.

Now the mirror is up and the averaging light photodiode (**SPD-A**) is looking at the opening curtain which is painted to have reflectivity equal to film. **IC-102** — after checking battery voltage — fires magnet **MG-1** to release the opening curtain. Trigger Switch **SW-103** opens to signal movement of the curtain. (There is an adjustable delay circuit with **C-101** and **VR-102** to set slit width at fast speeds.) Light from the subject is focused on the opening curtain (and later the film) through the

stopped-down lens. A portion of this light reflects back to the photodiode on **IC-103**.

IC-102 initiates integration of reflected light with time (the equivalent of exposure) with a signal from pin 80 to pin 14, **IC-103**. Voltage on the integrator's output begins to increase at a rate proportional to light intensity at the film plane. The same voltage appears on the second input of comparator **CP-M**. When voltage levels at both inputs of **CP-M** are equal, exposure for that particular film is correct. **CP-M** switches states and the voltage at pin 57, **IC-102** falls to zero.

Pin 57 is connected to transistor **Q-202** on the shutter board. **Q-202** stops conducting current through magnet **MG-2** which has been latching the closing curtain and the exposure ends. As the mirror returns, **SW-101** opens to reset the IC's into metering mode.

2. Automatic by Spot Measurement

With the mode set to "Auto," pressing the "Spot" button changes exposure control from off-the-film to a type using digital memory. Part of the light from the portion of subject covered by the focusing area of the viewfinder screen is reflected to the spot photodiode (**SPD-S**). The CPU controls which photodiodes are used according to mode. SPD selection is through pins 6 and 7, **IC-103**.

IC-102 converts BV voltage along with aperture and ASA data to a binary code, then sends the information to the CPU inside **IC-101**. Subject brightness at the moment the **Spot Button** was pressed is stored; however, changes in aperture and ASA will still affect auto shutter speed. Each time the **Spot Button** is pressed (before exposure) a new spot reading is added to the exposure calculation and averaged with previous readings. The process continues until a total of 8 spot readings are taken, then subsequent measurements cause the first readings to drop off.

When the release button is pressed and the mirror closes **SW-101**, the last exposure indicated by the bar graph in the display is stored in **IC-101's** digital memory. The CPU sends an exposure program to **IC-102** telling it to ignore **IC-103's** off-the-film integration and instead to set up its own integration. Capacitor **C-104**, connected to pin 44, **IC-102**, will be charged by a constant current. Magnitude of the current is set proportional to the shutter speed calculated by the CPU. Binary speed information is decoded by **IC-102 (DAC)** to analog voltages. Faster speeds call for higher currents.

When the **Trigger Switch** opens, current from **IC-102** begins to charge capacitor **C-104**. Voltage on **C-104** is also connected to one input of comparator **CP-M**, the same as used for off-the-film exposure. When the voltage reaches a preset level equal to that on **CP-M's** other input, the comparator switches states to turn off **Q-202** and release the closing curtain.

As the mirror returns and **SW-101** opens, the IC's are reset to auto exposure using average light readings.

3. Automatic by Memory

Closing the "Memory" switch in either automatic mode instructs the CPU to store the brightness reading used in the last exposure. That is, after the shutter has run, the same speed will be used for all subsequent exposures regardless of light conditions. Changes in aperture and ASA will cause comparable changes in shutter speed. The condition will remain for about one hour or until the "Clear" switch is closed.

The first Auto-by-Average exposure in Memory mode will be off-the-film using IC-103's integrator. All other exposures will be controlled by IC-102 in the same manner as for Auto by Spot.

4. Manual by Average

Manual speeds are selected by turning the speed selector ring behind the lens. A variable resistor (TV-VR) under the Shutter Board is turned by a gear coupled to the speed selector ring. In manual mode the CPU instructs IC-102 to convert voltage changes from the TV-VR to binary code along with voltage changes from brightness, aperture, and ASA.

The CPU calculates proper exposure based upon ASA and light. The difference between the correct exposure and that resulting from aperture and speed settings is indicated by the bar graph in the viewfinder display. When the two are equal, the end of the bar graph is at the index mark in the center.

Shutter speed is controlled by IC-102 in the same manner as Auto by Spot. The current to charge C-104 is proportional to the manual speed selected.

5. Manual by Spot

Exposure calculations by the CPU are based upon an average of up to eight spot light readings. The bar graph indicates the result of this average. Shutter speed control is the same in all manual modes, since the speed selected will be used regardless of exposure error.

6. Highlight and Shadow

In any "Spot" mode of operation, pressing the "Hi. Light" or "Shadow" switches will change the indicated exposure. "Shadow" shortens exposure time by about 2½ Ev, while "Hi. Light" extends exposure time by 2 Ev. In auto modes, the actual shutter speed is changed accordingly.

7. Off-The-Film Flash Exposure Control

When a suitable flash, such as the T-32, is installed on the camera, operation changes to Off-The-Film Flash mode. All other modes are cleared by the flash operation. The CPU gathers light, ASA, and aperture conditions, then calculates an exposure. If shutter speed is less than 1/60, the flash will be triggered during exposure. Light from the flash is integrated by IC-103, the same as Auto by Average mode. When a proper exposure has been made, pin 48, IC-102 goes high signaling the flash through its dedication contact. The flash quenches, the shutter times out at 1/60 second, and the system resets for the next exposure.

After a flash exposure, the strobe LED (viewfinder) will flicker if exposure was correct. For insufficient light, the "Under" LCD will flicker and the "Over" LCD flickers to indicate too much light.

The Sync Switch does not connect directly to the hot shoe contact. When the opening curtain runs to close the Sync Switch (X-Contact), pin 59, IC-102 is connected to the chassis or B+. Pin 50, IC-102, then goes low to turn on transistor Q-101. Q-101 switches B+ to the gate of an SCR which turns on to connect the hot shoe contact to the body. If the auto speed will be faster than 1/60, the SCR is not switched on and the flash does not fire.

Connecting the positive side of a 2v power source to the shoe and the negative side to the right-side dedication contact should set flash mode operation. The red LED indicating the flash symbol will light in the viewfinder and shutter speed will be 1/60.

Readout

The LCD viewfinder indication is driven by IC-104 situated under the flex circuit between the prism and rewind shaft. Capacitor C-302 between pins 3 and 4, IC-104, acts as a voltage booster (+/- 3v to Vcc) to provide the necessary 6 volts to operate the LCD. Power (Vcc) is supplied through transistor Q-301 (PNP) which is controlled by pin 54, IC-102.

As the CPU determines exposure and mode, that information is transmitted to IC-104 for decoding and display. Data transmission takes place about once every 100ms through a series line.

1. Data Sync signal is sent from pin 12, IC-101 to pin 11, IC-104.
2. Timing clock signal is sent from pin 10, IC-101 to pin 13, IC-104.
3. Series data is sent from pin 11, IC-104 to pin 12, IC-104.

The display is made up of 41 horizontal rows and back plates in three vertical rows. Voltage differences of 4.0v between any horizontal and vertical will result in that segment being darkened. There is a RAM included inside IC-104.

There is a backlight lamp for viewing the display in dark conditions. Pressing the "Lamp" switch sets the light on for about 8 seconds.

Battery Check

Turning the Mode Switch to "Battery Check" sets IC-101 to the check condition. IC-101 directs IC-102 to drive the Piezo Buzzer through pin 25 and the Timer LED through pin 41. The display is also involved:

1. When voltage is above 2.75v, the tone is steady and the LCD and LED are steady.
2. When voltage is between 2.65v and 2.75v, the tone, LED, and LCD are intermittent.
3. Below 2.65v there is no indication.
4. Below 1.9v there is a constant warning tone.

Remember also, when voltage is below 2.65v, release is inhibited but will reset by itself when new batteries are installed.

Winder Dedication

There are five winder or motor drive dedication contacts on the camera's bottom. From front to back they connect as follows:

1. **SF Switch** located near the battery case. The switch is closed, shorting the contact to chassis when there is no film on the spool.
2. **RK Switch** which closes, shorting the contact to chassis when the rewind button is pressed.
3. & 4. **MD Switch** located near the contacts. With the mirror down, the contacts are shorted together. With the mirror up, #3 is open and #4 is shorted to chassis.
5. **U Switch** located on bottom rewind side. The switch closes, shorting the contact to chassis when film door is open.

Self-Timer

Closing the **Timer Switch (SW-104)** connects pins 20 and 26, IC-101. This programs an electronic delay between the time SW-101 closes (mirror rises) and when IC-102 signals MG-1 to release the opening curtain. The timer interval is 12 seconds with flashing LED and buzzer to call plenty of attention to the situation.

II. EXTERNAL TESTS

1. Try operating the camera in mechanical mode, "B" and "60." There should be normal shutter and transport function. If not, remove the bottom cover, then check the shutter charge gears, mirror charging lever, and release lever.
2. Move the **Mode Switch** to "Battery Check." There should be audible and visual (LED) indications. If not, test battery voltage. Below 2.65v the LED and Buzzer will not function. If the voltage is above 2.65v, there may be a power circuit problem or possibly a dirty battery contact.
3. Set the **Mode Switch** to "Auto," the shutter speed control ring to 1/125, then press the release button one-half stroke. The LCD in the viewfinder should show a bar graph and list shutter speeds from 1 through 2000. If

there is no display and no battery check in the previous step, there is a power circuit problem. Test power consumption.

4. Watch the viewfinder LCD as you change aperture, ASA, and scan different subject brightnesses. The bar graph should change one Ev for each Ev change you make with the controls. If changes are erratic, wipers are dirty or making poor contact. If there is no change with brightness, look for the word "Memo" in the LCD. If it is flashing, memory has been set. Move the control switch to "Clear" to reset the system. Still no change in the bar graph with light suggests a flex or IC problem.
 5. If LCD response was normal in step 4, press the "Spot" button while the circuits are on. The word "Spot" should appear and the bar graph should remain unchanged with light. Try several more tests for spot metering on different subject brightnesses. The bar graph should adjust to an average of the settings. Also, test "Highlight" and "Shadow" buttons. Finally, move the control switch to "Clear." The "Auto" mode with bar graph should reappear. If any functions fail, the most likely cause is poor switch contact or a broken connection to the top cover.
 6. See if "Auto" exposure (without "Spot") delivers speeds near to bar graph indications. (Be sure to use film or similar material in front of pressure plate.) If the speeds sound fast, check the aperture. If speeds do not match LCD indications, there is an off-the-film circuit problem.
 7. See if "Spot" mode speeds correspond to the bar graph. If not but the "Auto" speeds do, there is a possible problem with IC-102 or the variable resistors. If speeds in steps 6 and 7 are both wrong, there is a problem with MG-2's circuit or the timing switch.
 8. Test several shutter speeds in "Manual" mode. If the speeds are incorrect, but "Spot" speeds are normal, suspect the TV-VR under the shutter board. If manual speeds are normal but "Spot" are not, there is a logic problem between IC-101 and IC-102 — probably an open connection.
 9. Apply 2 volts (—) to the wind-side flash dedication contact with the mode set to "Auto" and circuits on. The "Flash" LED should appear in the viewfinder and the shutter speed should be near 1/60.
 10. Try the auxiliary functions such as self-timer and LCD lamp switch.
- Finally, always keep these important facts in mind:
- A. "Auto-Average" exposure is controlled by IC-103 at the time of exposure and may not be what the LCD indicates in advance.
 - B. "Spot" and "Manual" exposures are calculated in advance by the CPU and are indicated by the LCD. Those exposures should *always* equal the indication.

III. EQUIPMENT AND GENERAL INFORMATION

A. Tools and equipment needed to carry out testing procedures in this guide:

- Grounded soldering iron
- DVM
- Oscilloscope
- Power supply
- Zero ohm test probe
- 1000 ohm probe

B. Power Consumption:

All measurements made with typical camera connected through a DVM to a regulated 2.9v power supply.

Circuits off (clock on)	17 micro-amps
Circuits on	0.6 ma
Shutter open	7.5 ma
Battery Check	9 ma
Flash mode	6 ma
Self-timer	12 ma

C. Typical coil resistance:

Opening curtain magnet, **MG-1** . . . 54 ohms. Measure between **Q-201**'s collector and the leg of **C-210** nearest the front of the camera.

Closing curtain magnet, **MG-2** . . . 580 ohms. Measure between the body and **Q-202**'s collector, the pin nearest the front.

D. Preparation for troubleshooting:

1. All DVM and scope measurements should be made with reference to the negative side of the power supply. For convenience, you may want to solder a short wire to the board at **TP-2**, then use that as a reference.
2. Most tests can be made with only the top cover removed. If the bottom cover is removed, you will need to connect a power supply or use a cut-off bottom cover to hold the batteries.
3. Use a strap lug for **B+** or **Vcc** source.
4. If you need to power up the circuits with lens off, first press the small black button near the red index dot on the bayonet ring.
5. Remove the cover plate in front under the mirror to gain access to **MG-2** and the shutter board.
6. The index mark straight to the back on the ASA resistor is ASA 100. Zero exposure compensation is the mark at two o'clock.
7. With the top removed, logic switches for "Spot," "Clear," "Memo," etc., are disconnected. To program those modes, use tweezer tips to momentarily connect wire solder pads or pins on **IC-101** as indicated:
 - "Spot" Gray to Red or Pins 16 and 17
 - "Memory" . Yellow to Brown or Pins 18 and 14
 - "Clear" Yellow to Red or Pins 16 and 18

8. The circuit may be cleared by moving the **Mode Switch** to the battery check position.

9. Take care to avoid static electricity damage to ICs when covers are off the camera.

10. Take full advantage of the comprehensive viewfinder **LCD** to aid your troubleshooting. Check each function to determine what works and what doesn't. **ESTABLISH THE EXACT SYMPTOMS BEFORE YOU BEGIN TO TROUBLESHOOT.**

IV. ADJUSTMENT PROCEDURE

Trigger delay (**Timing Switch**), **BV**, and Direct Ev adjustments can be reached through a cutout in the front plate above the **Self-Timer Switch**.

If possible, use a power supply instead of batteries during adjustment. Set supply voltage at 3.0v.

1. Test manual speeds at 1/8 (117ms, +/-0) and 1/2000 (0.49ms, +/-0.2ms). Adjust 1/8 speed with **VR-101**. Adjust 1/2000 speed with **VR-102**, the trigger delay under the front leather nearest the wind side.

2. Set ASA 100, f-5.6, and LV-10, and mode to "Auto." Be sure "Spot" mode is not used and exposure correction factor on ASA dial is zero. Use film or surface of similar reflectivity on tester sensor face.

Try several test exposures, then adjust for near zero exposure error using **VR-110**, under the front leather nearest the lens. Check the exposure at higher ASAs (up to 3200) and fine tune if necessary using **VR-103**. Try to maintain +/- 0.3 Ev over ASA range.

3. Set ASA 100, f-4, "Auto" (not "Spot") and LV-11. Adjust **VR-105**, under the front leather at the center, so the **LCD** bar graph indicates 1/125.

4. Set ASA 100, f-4, "Auto," and LV-11. Press the "Spot" button; the index dot should indicate 1/125. Adjust using **VR-106**.

5. If auto exposure in "Spot" mode is not correct, **DAC** reference voltage may be incorrect. Set ASA 3200, correction factor to zero. Using a DVM, measure the voltage between **Vref** (DVM common lead) and **DAC** output at pin 46, **IC-102**. At room temperature, 21 degrees centigrade, the voltage should be 198mv. Adjust with **VR-108**.

V. IC CHECKS

IC-101

Pins 1, 2, 3. Battery check mode signals outputs. Voltage is normally near zero.

Pins 4, 5, 6. Control to IC-102 for which signals should be decoded. Typical traces shown.

Pins 7, 8. Integration capacitor selection control lines. Sets code for selection during release. To test, apply Vcc to SW-101 wire through 1000 ohm probe. ASA 6, pin 7 low, pin 8 high. ASA 100, pin 7 high, pin 8 low.

Pin 9 has no connection.

Pins 10, 11, 12. Exposure output to LCD. Pin 10 is timing signal, pin 11 is serial data, and pin 12 is sync. See scope traces.

Pins 13 to 20 are inputs from logic switches. ("Mode," "Clear," etc.) Common lines are pins 17, 18, and 20.

Pins 21 and 22 are battery negative.

Pin 23 has no connection.

Pins 24, 25, 26. Momentarily connecting each to pin 20 sets lamp on, battery check, or self-timer.

Pin 27 is the input from IC-102 to set flash mode. Vcc through a 1000 ohm probe should set flash symbol on LCD.

Pin 28 is the flash LED input.

Pin 29 is the exposure data from IC-102. See scope trace.

Pin 30 is the input from IC-102 to signal SW-101 closed (mirror up). First high stores exposure data, next high returns to metering mode. You can drive the circuit bonkers with random highs to pin 30.

Pin 31 is output to Memory LED on "Spot" button.

Pin 32 is output to Q-105 to operate LCD backlight lamp.

Pin 33 is output to Q-106 for strobe LED in viewfinder. Depends upon input at pin 28.

Pin 34 is output to IC-102 to turn on battery check LED. Should go high in "Check" mode if supply is above 2.75v.

Pins 35 to 42 are DAC output lines to IC-102. See scope traces.

Pin 43 is input from reset circuit. Vcc resets circuit.

Pins 44 and 45 are 500 KHz clock signal, probably for CPU.

Pin 46 is Vcc in.

Pins 47 and 48 connect to the quartz crystal. 32.8 KHz sine wave.

Pin 49 is Mirror Switch, SW-101, signal input. Goes low as SW-101 closes.

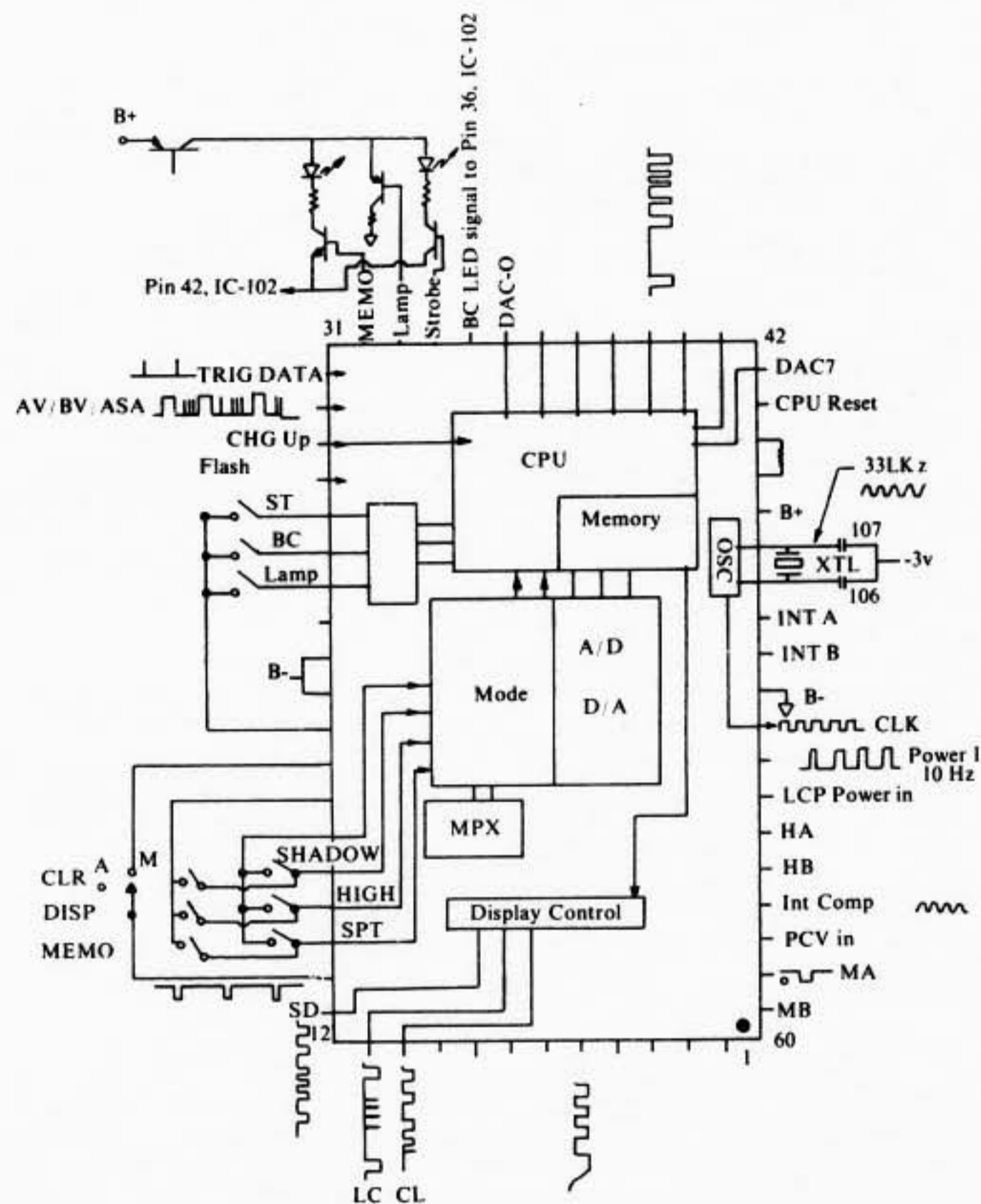

Pin 50 is the same as pin 27.

Pin 51 is battery negative.

Pin 52 is CLK output.

Pin 53 is the power signal to IC-102 for all circuits. Series of high pulses after release is pressed one-half stroke.

Pin 54 is signal to IC-102 to supply power to LCD. High when on.

Pin 55 is output to IC-103 that sets photodiode according to mode. High is "Average," low is "Spot."

Pin 56 signals IC-103 with low when SW-101 closes.

Pin 57 is integration compensation to IC-102.

Pin 58 is Piezo signal to IC-102.

Pins 59 and 60 are signals to IC-102 to charge MG-1's capacitor and release. Low signals release.

IC-102

Pin 1 is limiter output to IC-103's integrator. If light is above 1/2000 exposure, pin 1 goes high to set exposure time to 1/2000.

Pin 2 has no connection.

Pin 3 is IC-103's integrator input to CP-M. Vcc through a 1000 ohm probe should cause fast speed in "Auto." See scope trace.

Pins 4, 5 switch integration capacitors into IC-103's circuit. Normally low.

Pin 6 is ground.

Pin 7 is BV input from IC-103. 1.5v to 1.7v, 18mv/Ev.

Pin 8 connects to pin 15, IC-103; SPD anode. Typical voltage is 1.8v.

Pins 9 and 10 are integration capacitor control code from CPU. See pins 7 and 8, IC-101.

Pins 11, 12, 13 are decoding control inputs from CPU. See scope traces.

Pins 15 and 16 are battery check mode inputs from pins 1, 2, IC-101.

Pins 17 and 18 are MG-1's control signals from the CPU. B- through a 1000 ohm probe should cause M-1 to "click."

Pin 19 is the Piezo input from CPU.

Pin 20 is integrator compensation input from CPU.

Pins 21 and 22 are mode control from CPU. (Pins 56, 55, IC-101.)

Pin 23 is signal from CPU to power LCD.

Pin 24 is "power on" signal from IC-101. Should go high when release is pressed one-half stroke.

Pin 25 is CLK in.

Pin 26 is B-.

Pin 27 is reset signal to IC-101 when battery voltage comes up to 2.90v.

Pins 28 to 35 are DAC data from IC-101. See scope traces.

Pin 36 is input signal for LED. Vcc through a 1000 ohm probe should light LED.

Pin 37 is trigger output to CPU.

Pin 38 is Ev data out to CPU. See scope trace.

Pins 39 and 40 are outputs to CPU to indicate flash is on (40) and charged (39). Pin 39 voltage should fall from near Vcc to near zero when flash charges. (B- through 1000 ohm probe to pin 48).

Pin 41 is Self-Timer LED drive signal to Q-401. Voltage near zero to turn on LED.

Pin 42 is the "go" signal to CPU if battery voltage is above 2.65v. Series of low pulses stop when battery voltage is low.

Pin 43 connects to C-105.

Pin 44 is integration current charging C-104 for "Manual" and "Spot" shutter timing. See scope trace. Vcc through a 1000 ohm probe should result in fast manual speed.

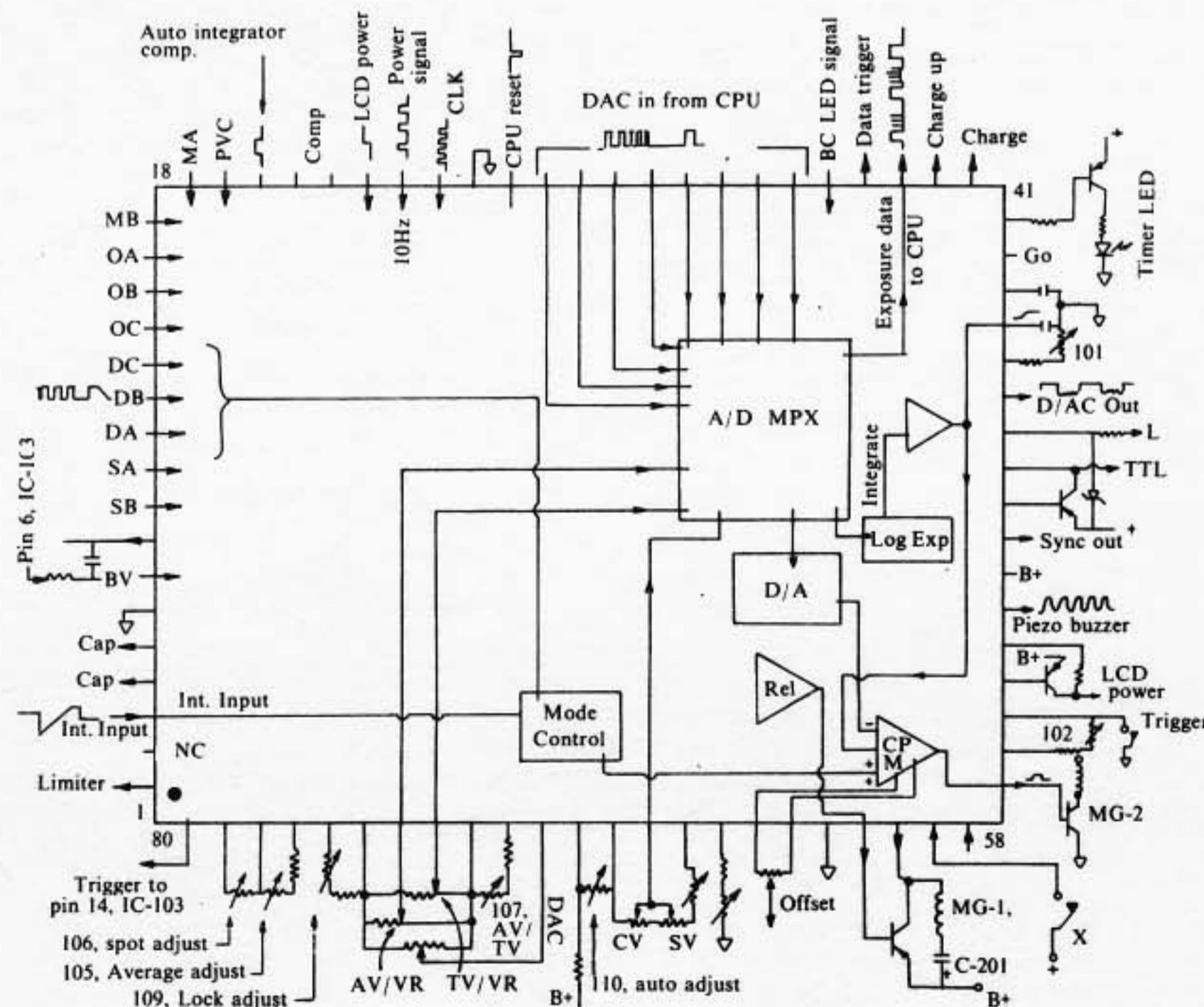

Pin 45 is manual speed calibration input from VR-101. Vcc through 1000 ohm probe should result in fast speed.

Pin 46 is DAC output. See scope trace.

Pin 47 is flash mode signal from shoe contact. B- through 1000 ohm probe should set flash mode.

Pins 48 and 49 are TTL flash exposure output.

Pin 50 is sync signal output to trigger flash. Should pulse low when first curtain runs.

Pin 51 is Vcc in.

Pin 52 is Piezo drive signal. See scope trace.

Pin 53 is CLK out to IC-104.

Pin 54 is power signal to IC-104. Should be low to turn on display.

Pin 55 is Trigger Switch input. Should pulse low as first curtain runs. Vcc through a 1000 ohm probe should cause shutter to latch open.

Pin 56 is reference for Trigger delay.

Pin 57 is output to Q-202 to operate MG-2. Should go high during exposure, all modes.

Pin 58 is input from Reset Circuit. Voltage should pulse high as mirror rises.

Pin 59 is input from X-sync Switch. Voltage should be zero with shutter set and high after first curtain has run.

Pin 60 is charge signal to C-201, for MG-1. Voltage will pulse high at release, then fall to near zero to recharge C-201.

Pin 61 is release signal to Q-201 for MG-1. Pulses low for release.

Pin 62 is B- in.

Pins 63 and 64 are offset compensation. Voltage is near zero.

Pin 65 is reference adjust. Voltage is about 30mv.

Pin 66 is exposure compensation reference current. Near 2.7v.

Pin 67 is ASA input. See scope trace. Voltage is near 2.7v.

Pins 68 and 69 are "Auto" adjust connections. Voltage is near 2.7v.

Pin 70 DAC reference adjust voltage. Typical is near 1.8v.

Pins 71 and 72 are reference current to TV-VR. Typical voltage is near 1.8v.

Pin 73 is input from TV-VR. See scope trace. B- through a 1000 ohm probe should result in fast manual speeds.

Pin 74 is input from AV-VR. Typical voltage is near 1.8v. B- through a 1000 ohm probe should send bar graph full scale.

Pin 75 is AV-VR reference current. Typical voltage is 1.8v.

Pin 76 input from lock voltage adjustment. Typical voltage is near 1.8v.

Pins 77 to 79 are to BV adjustment circuit. Typical voltages are near 1.3v to 77 and 78. Near zero for 79.

Pin 80 is Trigger Switch signal to IC-103. Should pulse low during exposure.

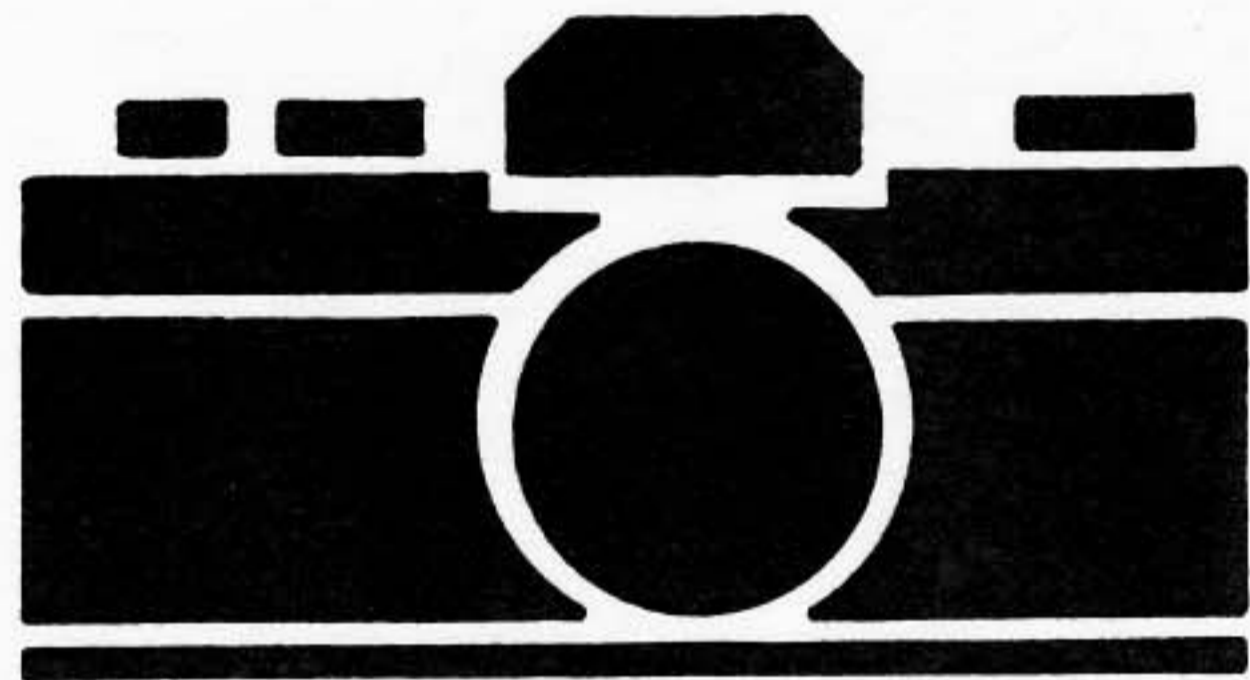

IC-103

This IC lives beneath the mirror box floor and can only be reached by removing the front plate. Its outputs are BV (measured at pin 7, IC-102) and integration (measured at pin 3, IC-102). If these are correct, the IC is probably working. If not, you may want to remove the front plate, then check connections according to the drawing.

Pin 16 is the BV output measured at pin 7, IC-102. Typical voltage is 1.5v to 1.7v, 18mv/LV.

Pin 10 is integration output measured at pin 3, IC-103. See scope trace for "Auto" mode.

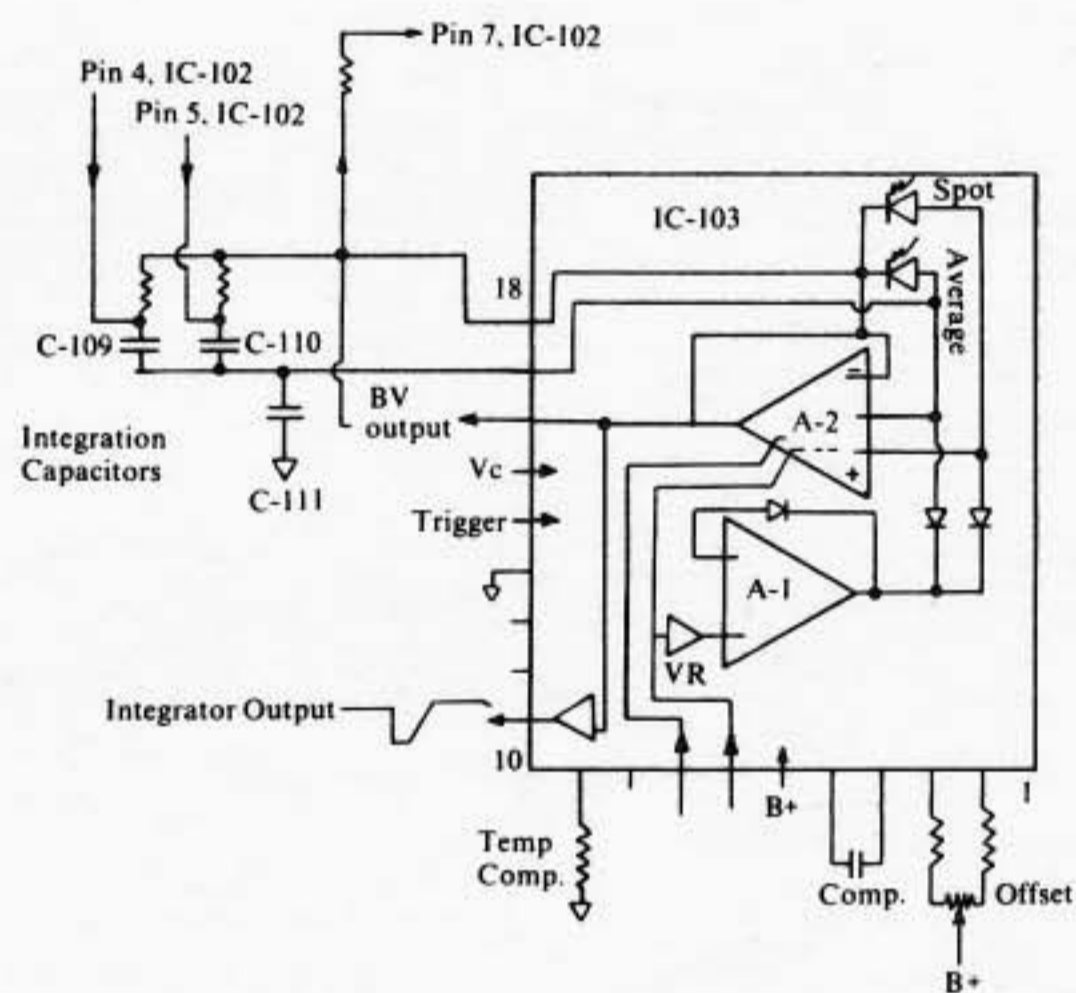

IC-104

This IC lives under a circuit board between the prism and ASA resistor. It is not easy to reach for tests, but important inputs can be checked at ICs 101 and 102. Its output, of course, is the LCD.

Pin 1 is CLK input. Check at pin 53, IC-102 and the white wire.

Pin 5 is Vcc in from IC-102. Check at pin 54, IC-102.

Pin 6 is B-.

Pin 11 is data sync signal from IC-101. Check scope trace at pin 12, IC-101 and the green wire.

Pin 12 is serial data in. Check scope trace at pin 11, IC-101 and the yellow wire.

Pin 13 is data clock signal in. Check at pin 10, IC-101 and the blue wire.

If there is no display, check for proper connections to pins 3 and 4 and from there to capacitor C-302. This is the 6-volt power source for the LCD.

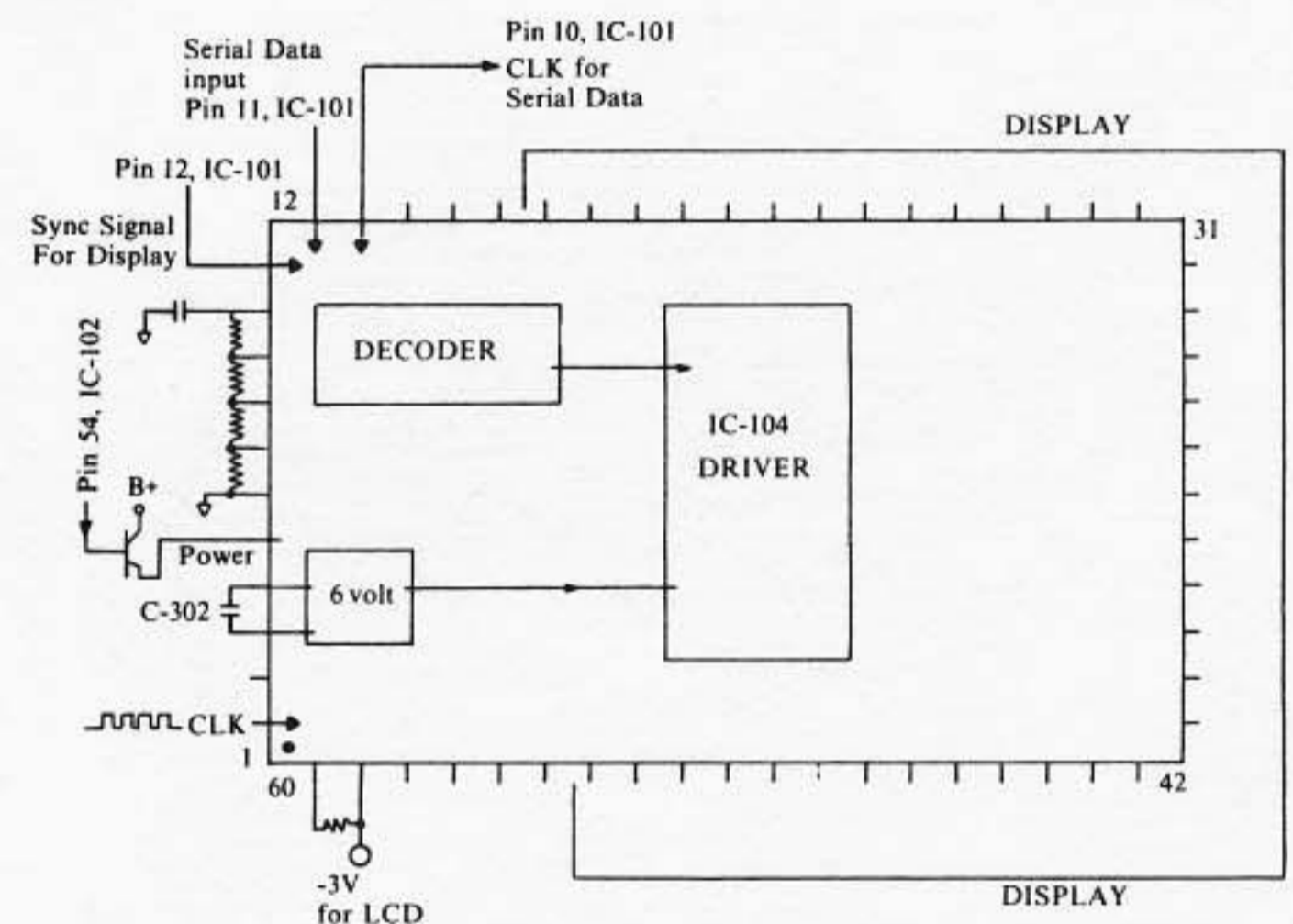

V. TROUBLESHOOTING

TRUBLESHOOTING FLOW CHART INDEX

Camera symptom _____	Flow chart	Camera symptom _____	Flow chart
No LCD		Shutter slow or open in	
No battery check	1-A	“Manual” and “Spot Average”	4-C
No shutter operation		“Auto Average” speeds normal	
Excessive battery usage	1-B	LCD normal	
LCD bar graph high or over		Shutter fast or running	
“Spot Auto” speeds fast	2-A	through, “Auto” and “Manual”	4-S
“Auto” speeds fast or normal		LCD normal	
“Manual” speeds normal		Mechanical speeds normal	
LCD bar graph low or under		Shutter fast in “Auto Average”	
“Spot Auto” speeds slow	2-B	“Manual” and “Spot” speeds	4-E
“Auto” speeds slow or normal		are normal	
“Manual” speeds normal		LCD is normal	
LCD bar graph erratic		Shutter fast in “Manual”	
“Spot Auto” speeds erratic	2-C	and “Spot Auto”	4-F
Manual speeds normal		“Auto Average” speeds normal	
Shutter won't run		LCD is normal	
Mirror releases, stays up	3-A	“Manual” speeds incorrect	4-G
LCD normal		“Auto” speeds normal	
Mechanical speeds normal		LCD weak or not working	
Shutter won't run after	3-B	Shutter functions normal	5-A
first release unless reset		Exposure normal	
Shutter stays open “Auto”		LCD shows wrong characters	
and “Manual”	4-A	Exposure is normal	5-B
Mechanical speeds normal		Flash will not fire	6-A
LCD normal		Shutter functions are normal	
Shutter slow or open in		Flash control problems:	
“Auto Average” mode		see IC-Checks and Circuit Description.	
“Manual” and “Spot Auto”	4-B	Self-Timer not working	7-A
speeds are normal		LED or Piezo Buzzer are	
LCD normal		not functioning	7-B
		Self-Timer delay normal	

1. Power Circuit Malfunctions

A. External Observations

No LCD.
No battery check.
No shutter operation except mechanical.

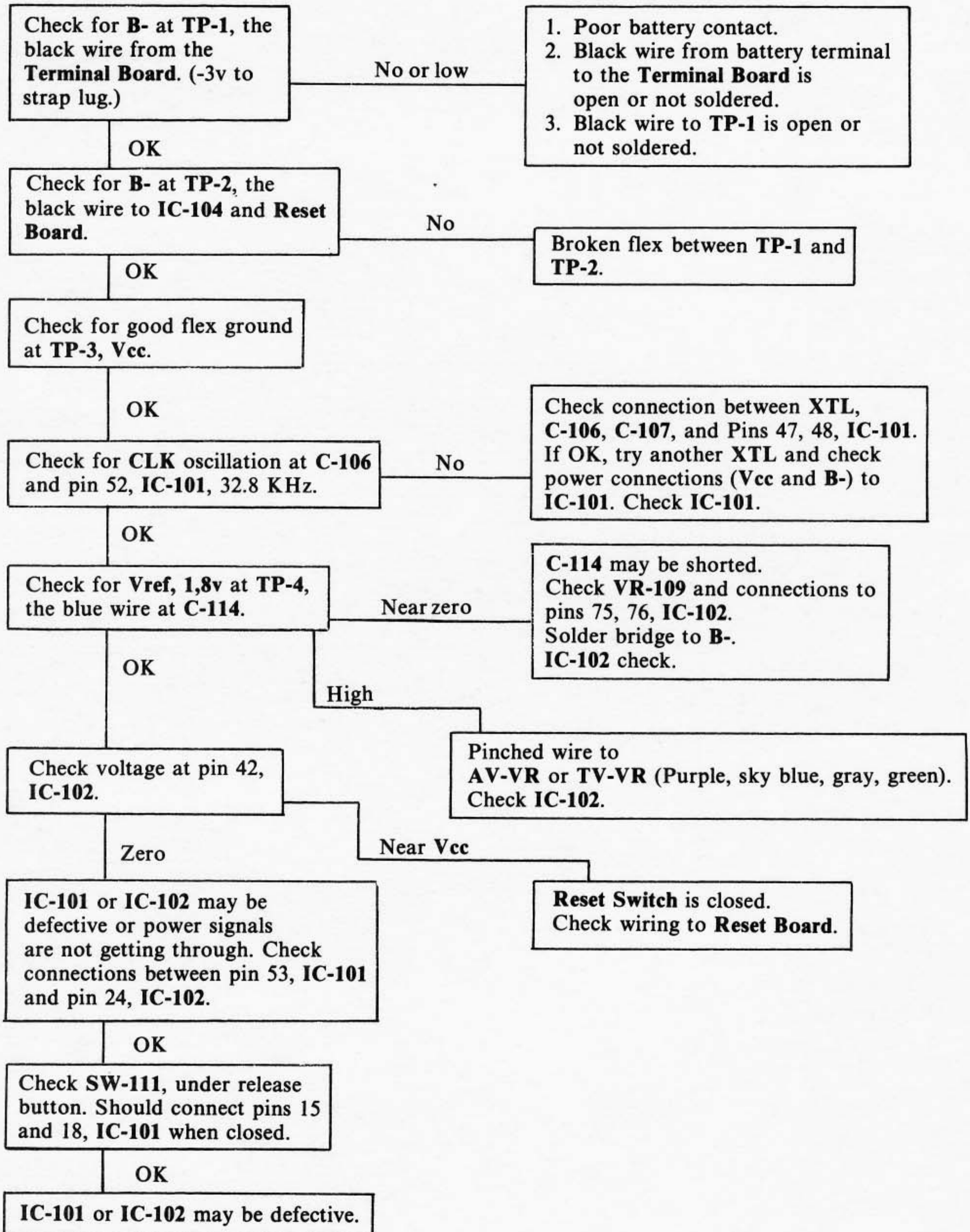

B. External Observations:

Batteries run down quickly.
Shutter functions may or may not be normal.
LCD may or may not function.

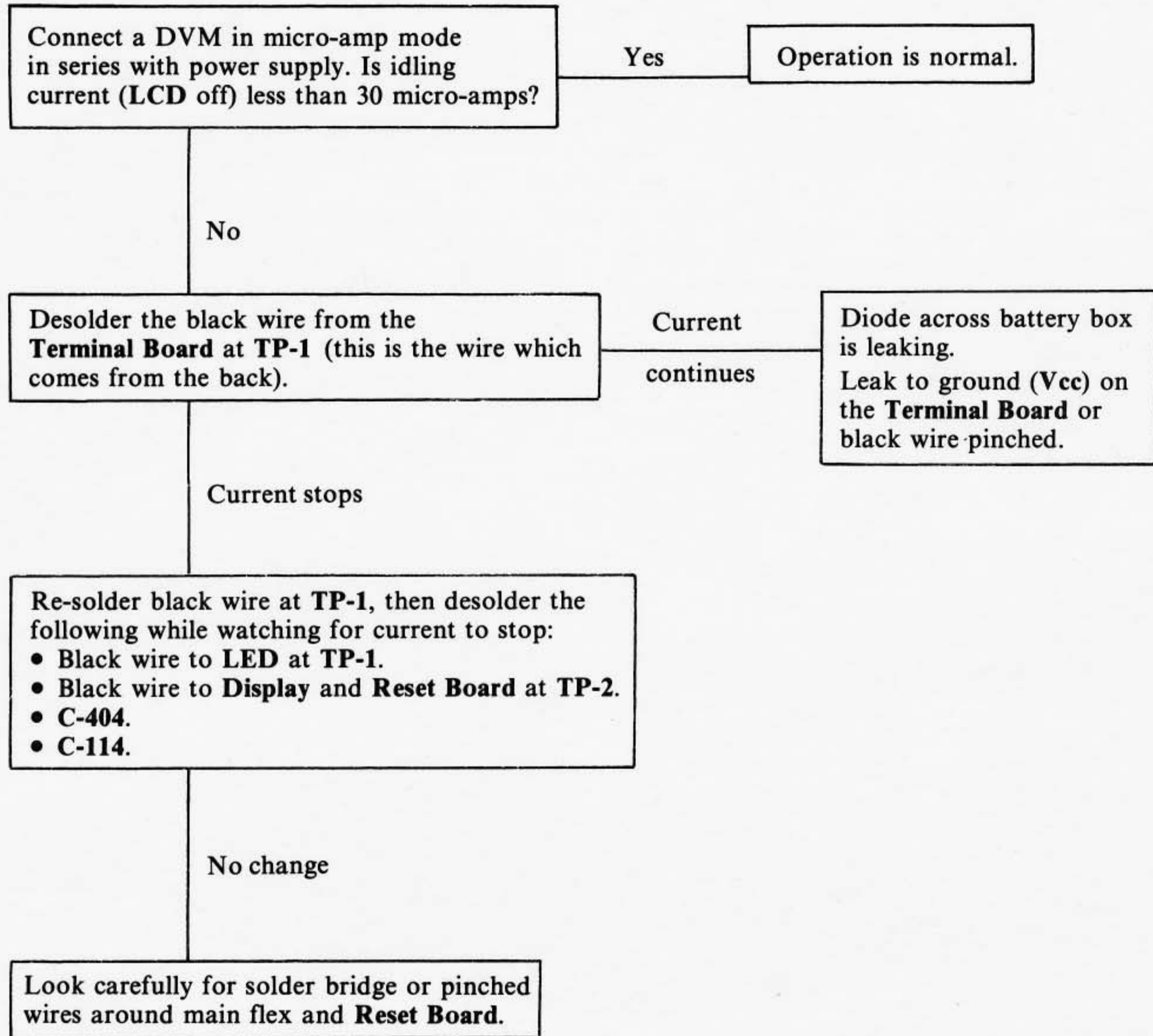

2. Metering Circuit Malfunctions

A. External Observations:

Bar graph indications are high or "over."
"Spot-Auto" speeds fast.
"Auto" speeds fast or normal.
"Manual" speeds normal.

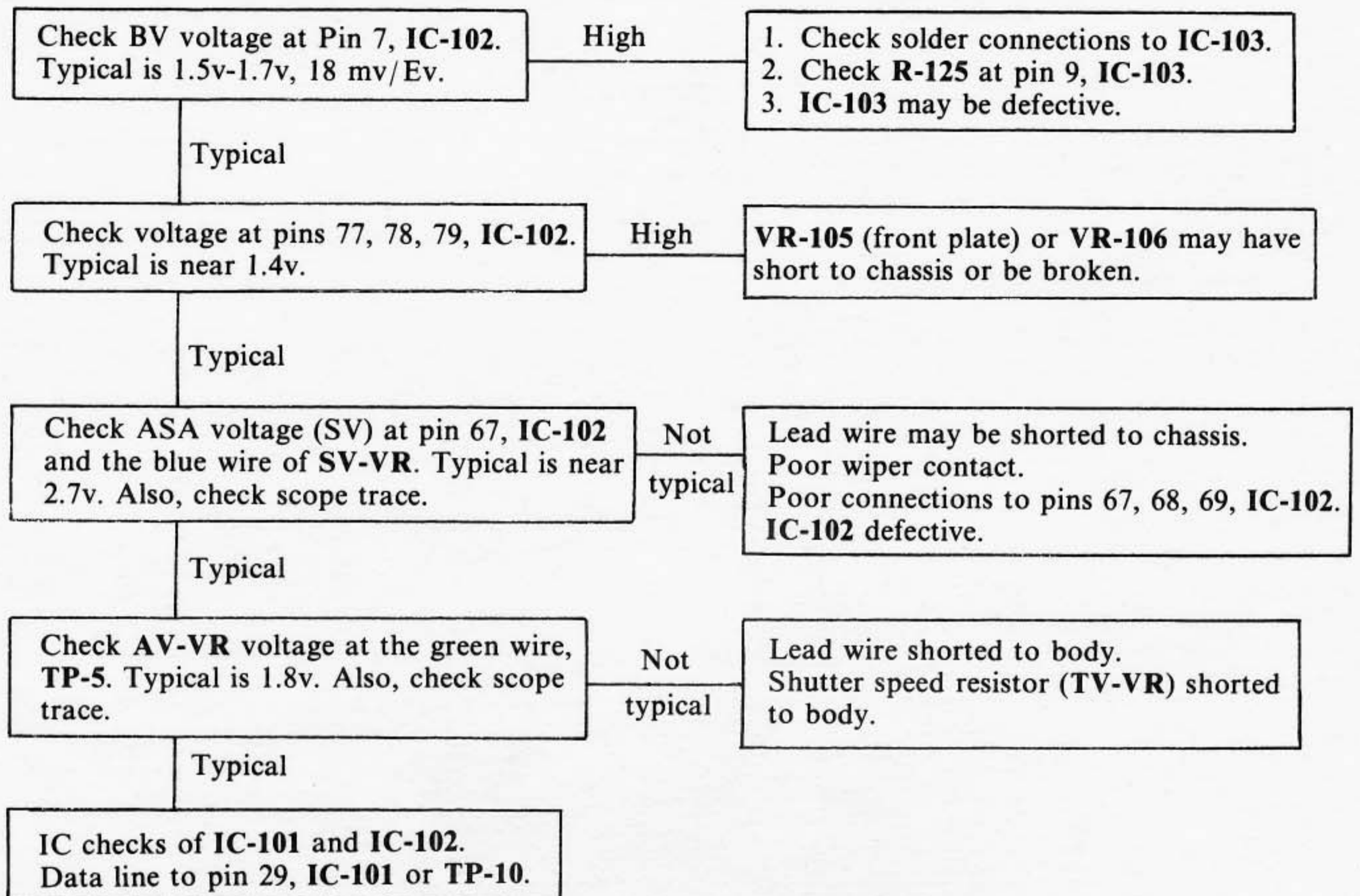

B. External Observations:

Bar graph indicates low or "under."
"Spot-Auto" speeds slow.
"Auto" speeds slow or normal.
"Manual" speeds normal.

First, check bar graph response to light, ASA, and AV changes to isolate problem. Follow the same procedure as 2-A, but look for the following:

1. Low voltage at pin 7, IC-102.
2. Open connections to VR-105 and VR-106.
3. Open connection to, or poor contact of, AV-VR wiper.
4. Solder bridge around SV-VR terminals or shorted wiring.
5. Short between pins 67, 68, 69, IC-102.

C. External Observations:

Erratic bar graph readings.
 "Spot-Auto" speeds erratic.
 "Auto" and "Manual" speeds may be normal.

1. Capacitor **C-108** (filter) may be open or not soldered. It is near **IC-103** but also connects across pins 7 and 8, **IC-102**. Value is .015 MF.
2. Check if bar graph is stable in BC mode. If so, check **R-130**, near **IC-101**.
3. Check for dirty wipers on **AV-VR** and **SV-VR**.

3. Release Malfunctions

A. External Observations:

Shutter will not release (or erratic) in "Auto" or "Manual," although mirror is up.
 Mechanical shutter function is normal.
 LCD is normal.
 Supply voltage is above 2.65v.

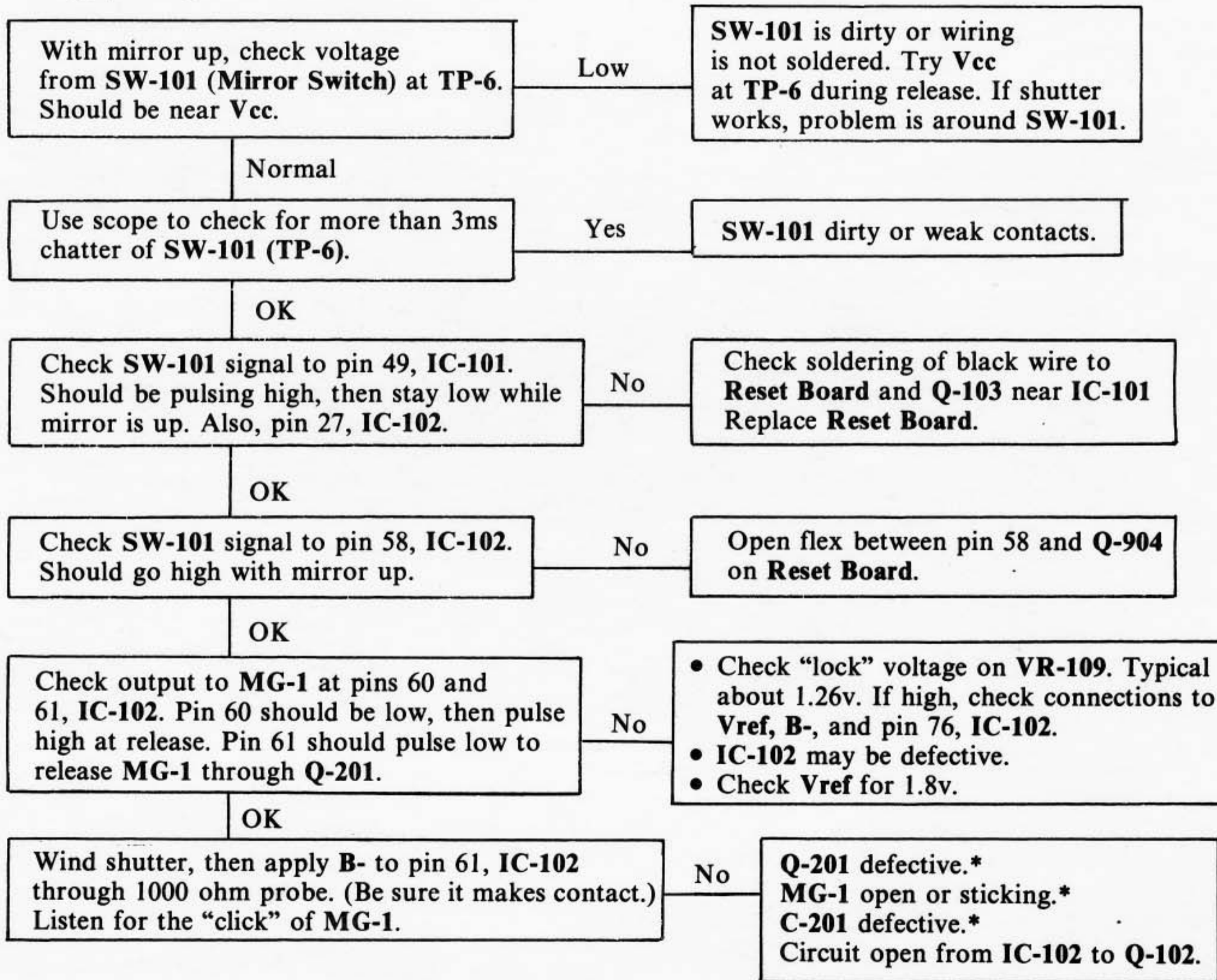

* Q-201, C-201, and MG-1 are on the board under the mirror. They can be reached by removing the cover plate in front.

B. External Observations:

Shutter releases once, then will not release again until circuit is reset.

LCD normal.

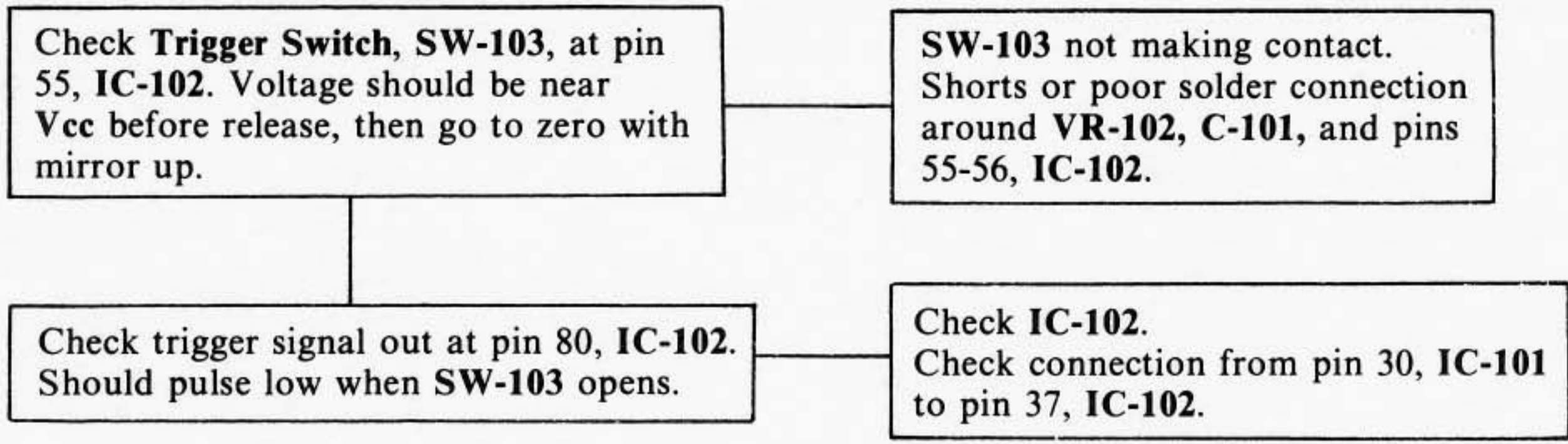

4. Shutter Malfunctions

A. External Observations:

Shutter stays open in "Auto" and "Manual."

Mechanical speeds OK.

LCD normal.

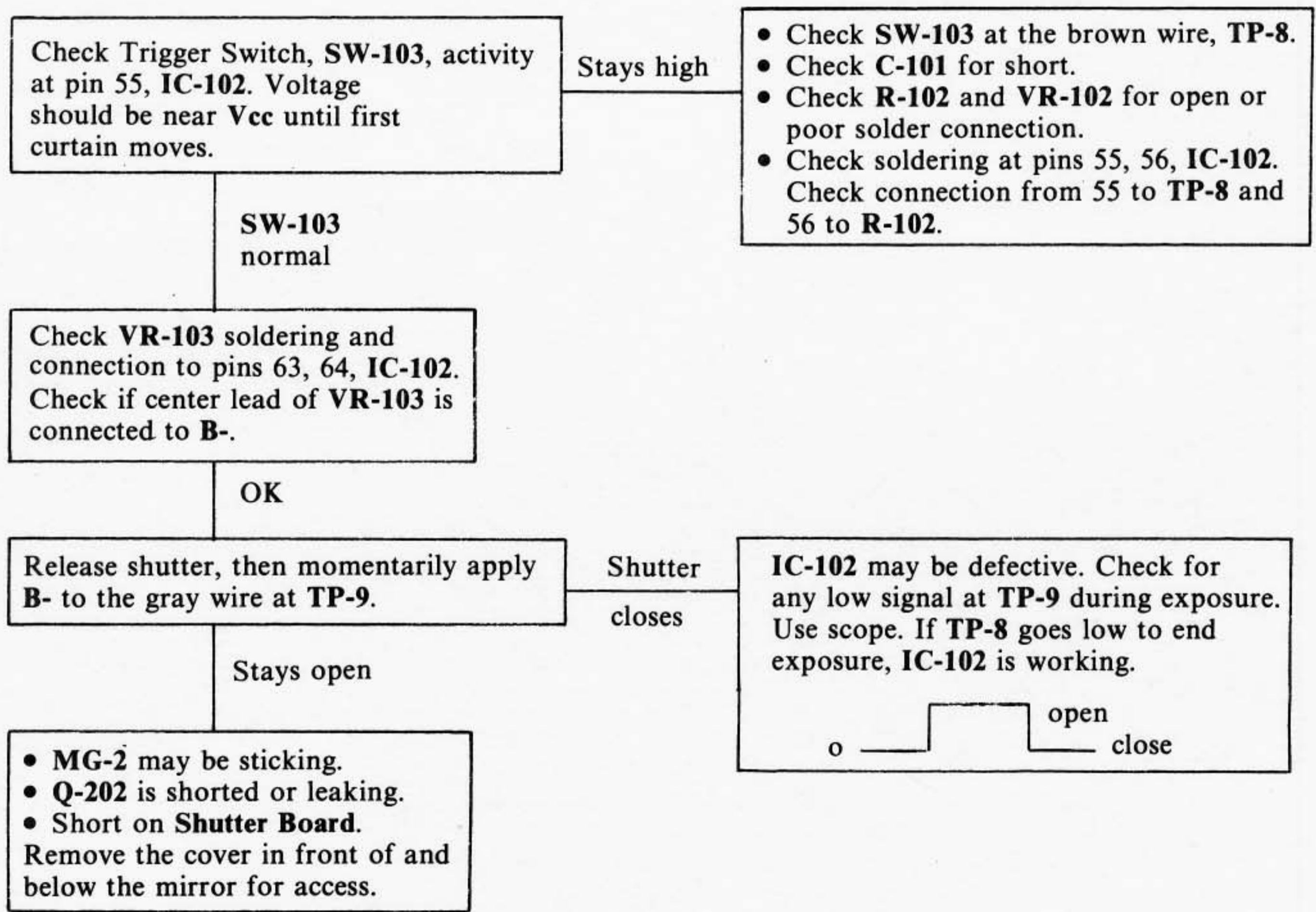

B. External Observations:

Shutter slow or open in "Auto Average."
Manual speeds normal.
"Spot-Auto" speeds normal.
LCD normal.

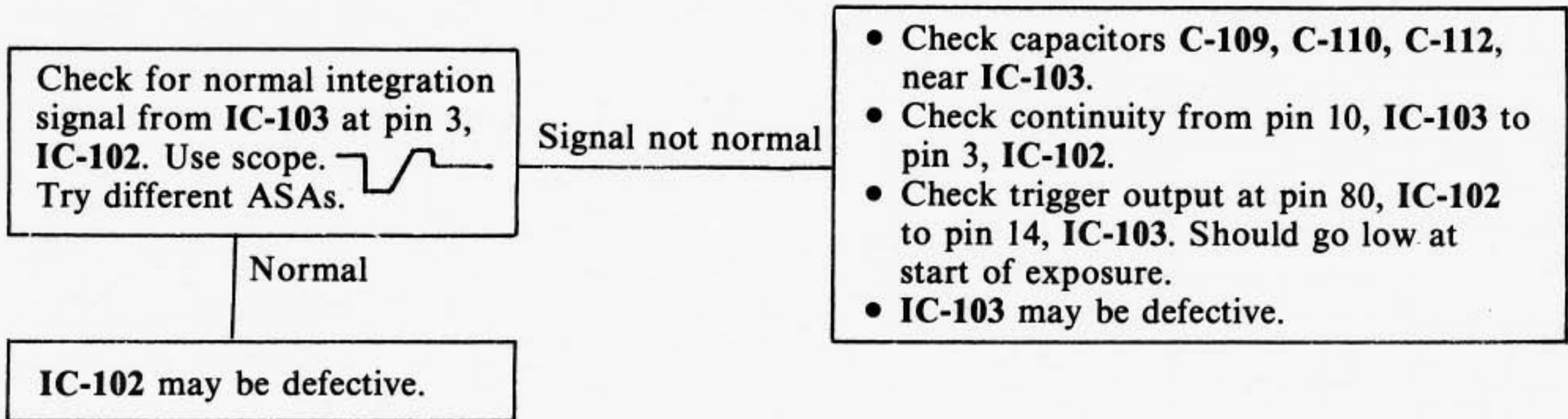

C. External Observations:

Shutter slow or open in "Manual."
Shutter slow or open in "Spot Auto."
"Auto" speeds normal.
LCD normal.

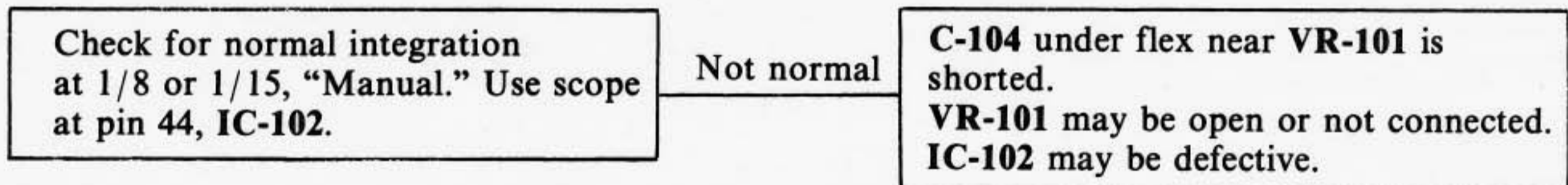

Note: Be sure LCD indicates correct "Manual" speed. If not, TV-VR is dirty.

D. External Observations:

Shutter fast or runs through "Auto" and "Manual."

LCD is normal.

Mechanical operation is normal.

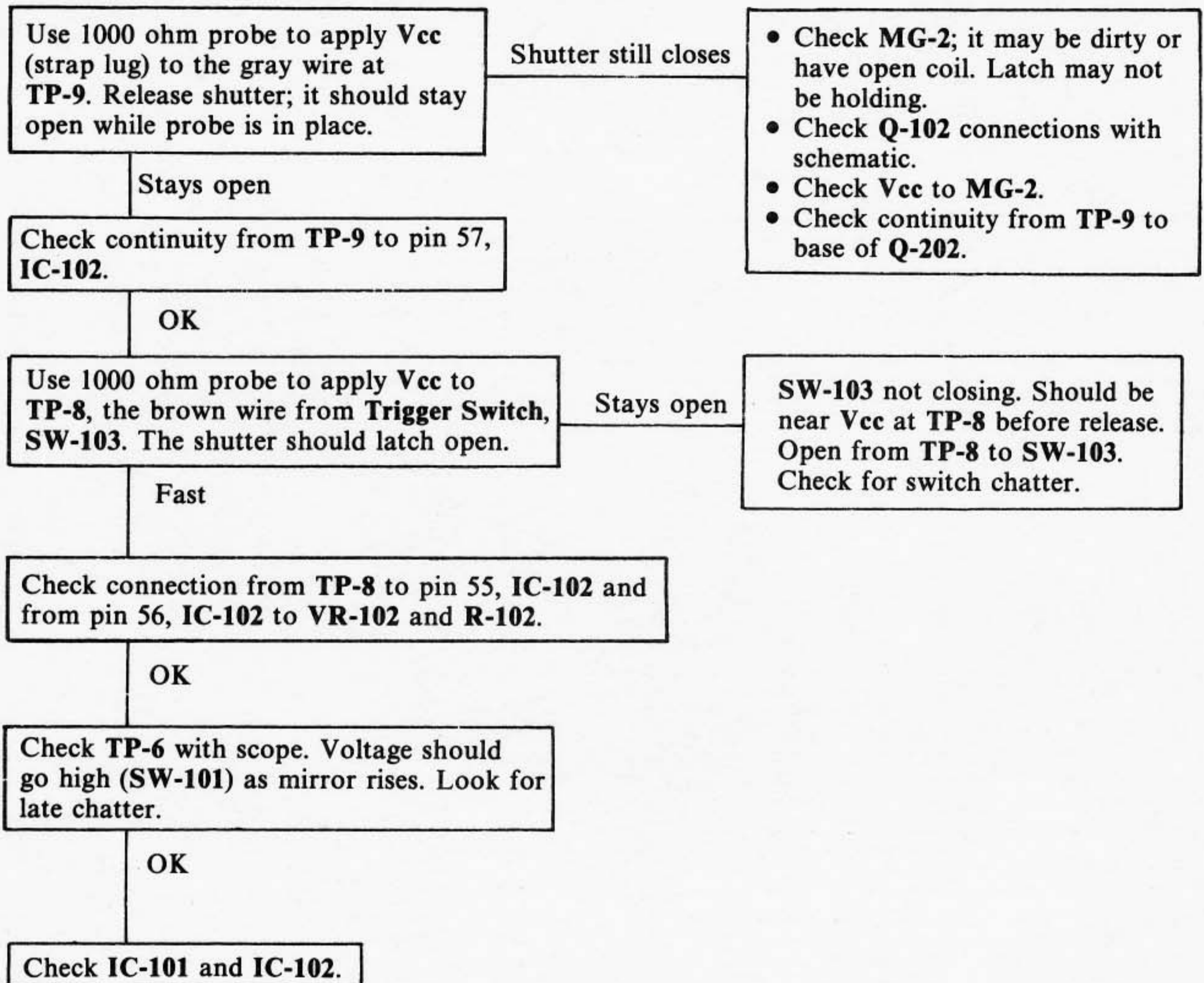

E. External Observations:

Shutter fast in "Auto Average."
"Manual" and "Spot Auto" speeds normal.
LCD is normal.

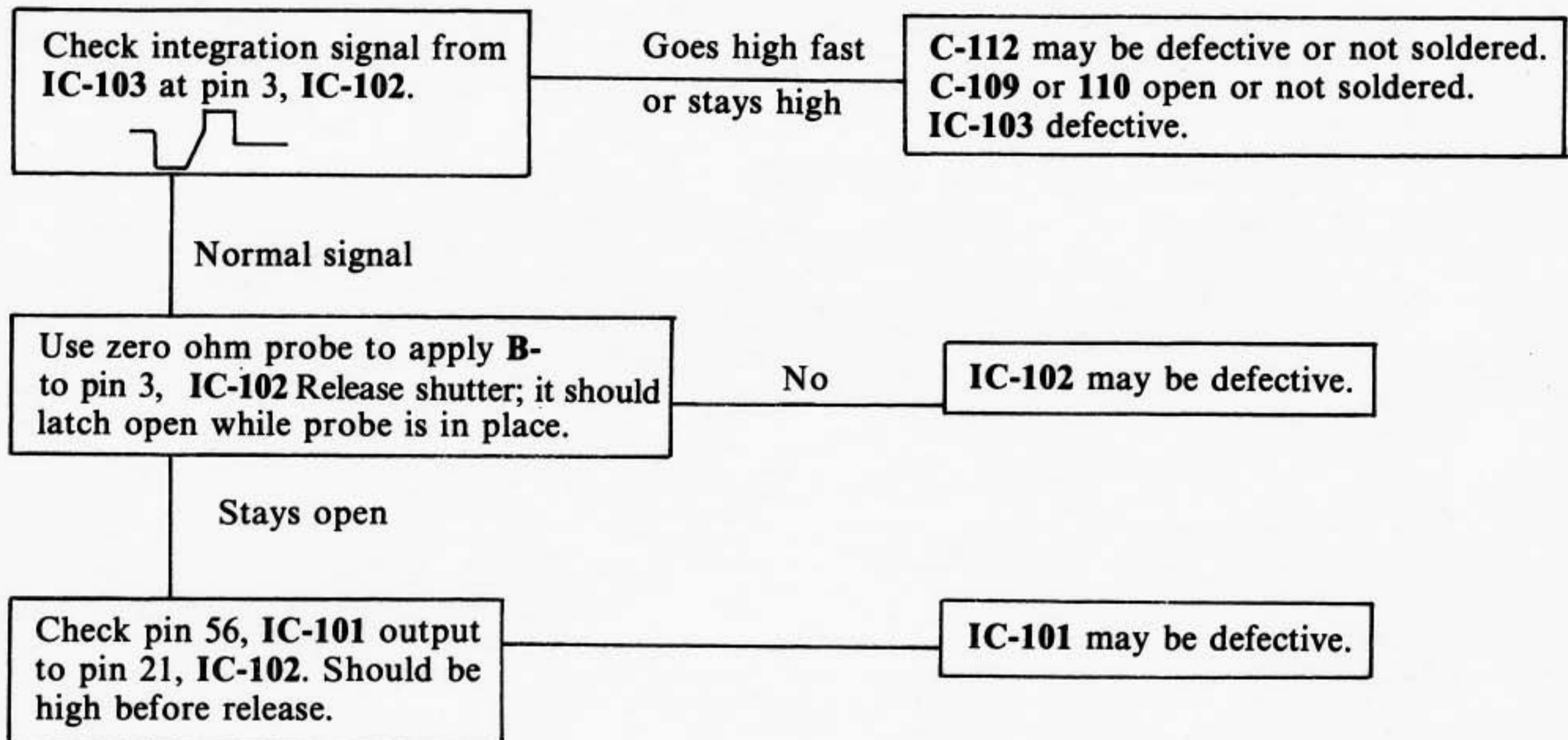

F. External Observations:

Shutter fast or runs through in "Manual" or "Auto Spot."
"Auto Average" speeds normal.
LCD is normal.

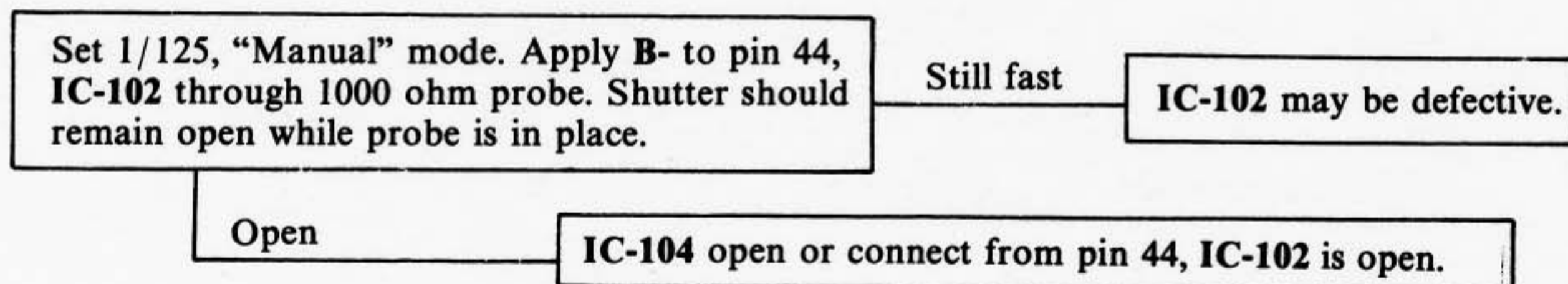

G. External Observations:

"Manual" speeds not correct or won't respond to adjustment.
"Auto" mode speeds OK.

1. Check each "Manual" speed with LCD. If LCD does not correspond to speed dial, TV-VR is dirty or not making contact.
2. If slow speeds are off, check VR-101 soldering.
3. If fast speeds are off, check:
 - A. VR-102
 - B. R-102
 - C. C-102
 - D. Trigger Switch chatter
 - E. Curtain overlap

5. Display Malfunctions

A. External Observations:

No LCD or weak or erratic.
Shutter functions normal.
Exposure is normal.

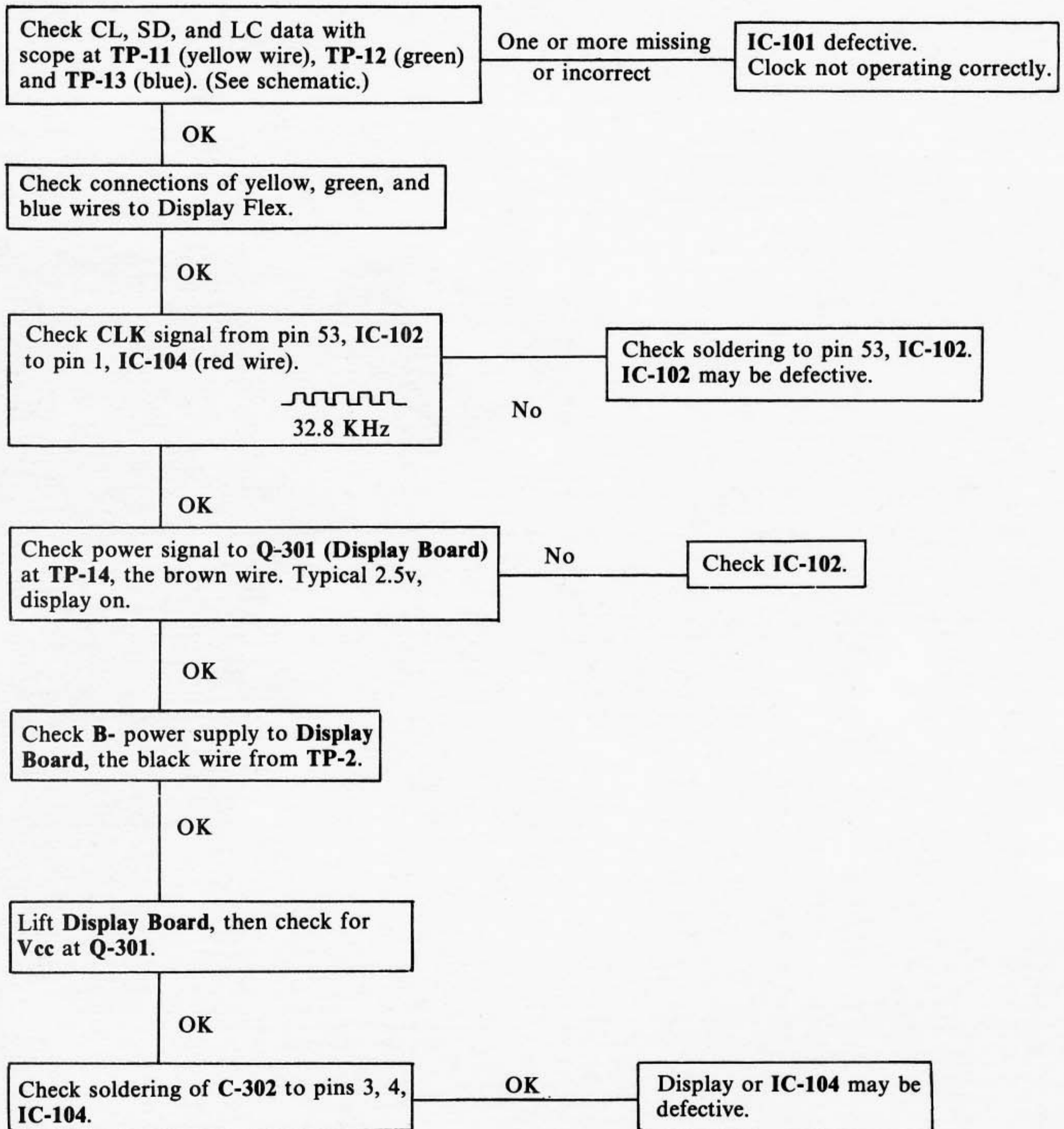

B. External Observations:

LCD works, but displays wrong characters for mode.

Shutter function appears to be normal.

Look for poor solder connections at wires to **Display Board**.

6. Flash Malfunctions

A. External Observations:

Flash will not fire.

“Flash” mode selected OK.

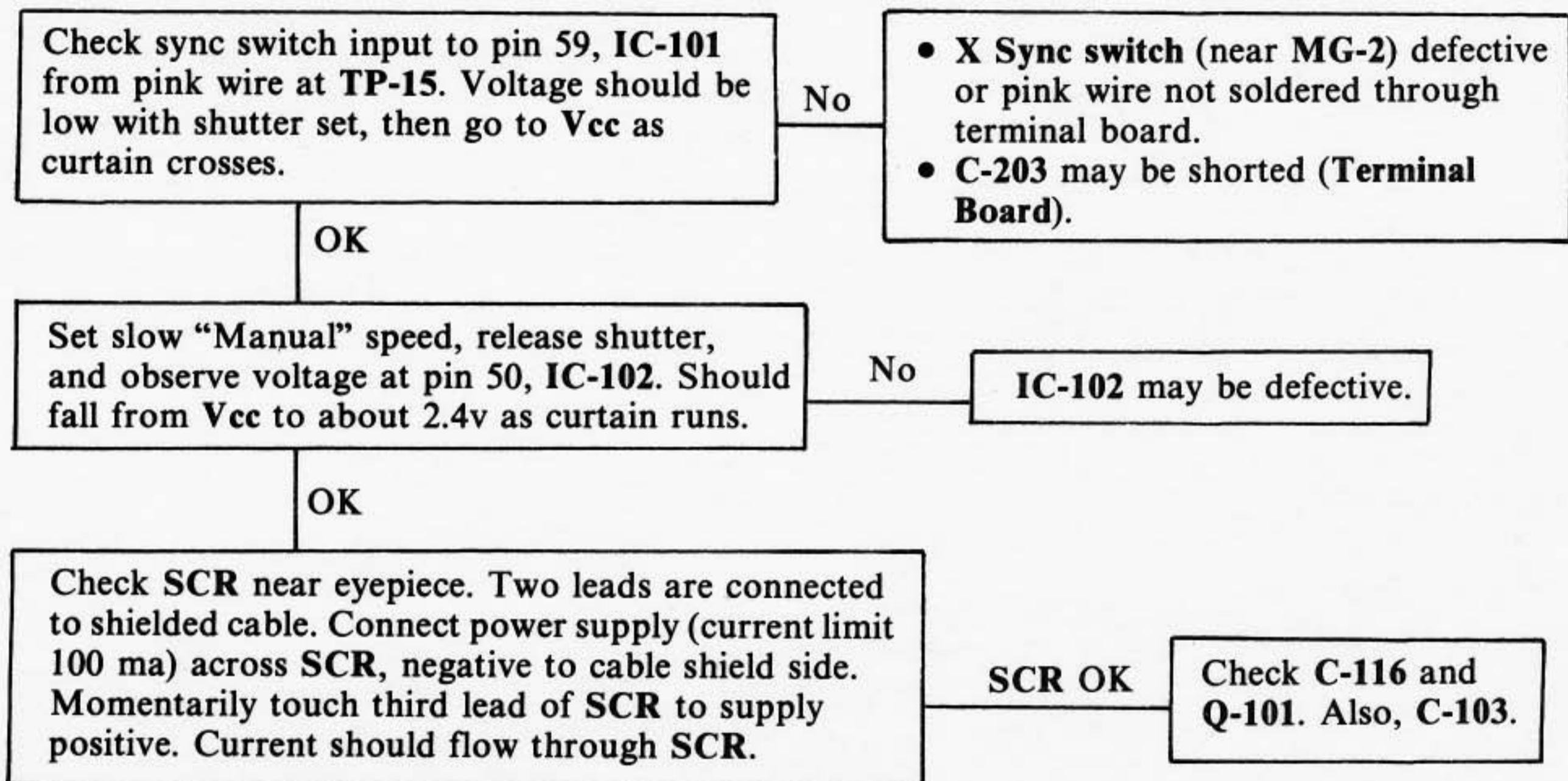

Note: With top off, shield side of cable to SCR must be grounded to strap lug for flash socket to work. Also, mirror safety switch connects flash socket to SCR through center lead of shielded cable.

7. Auxiliary Functions

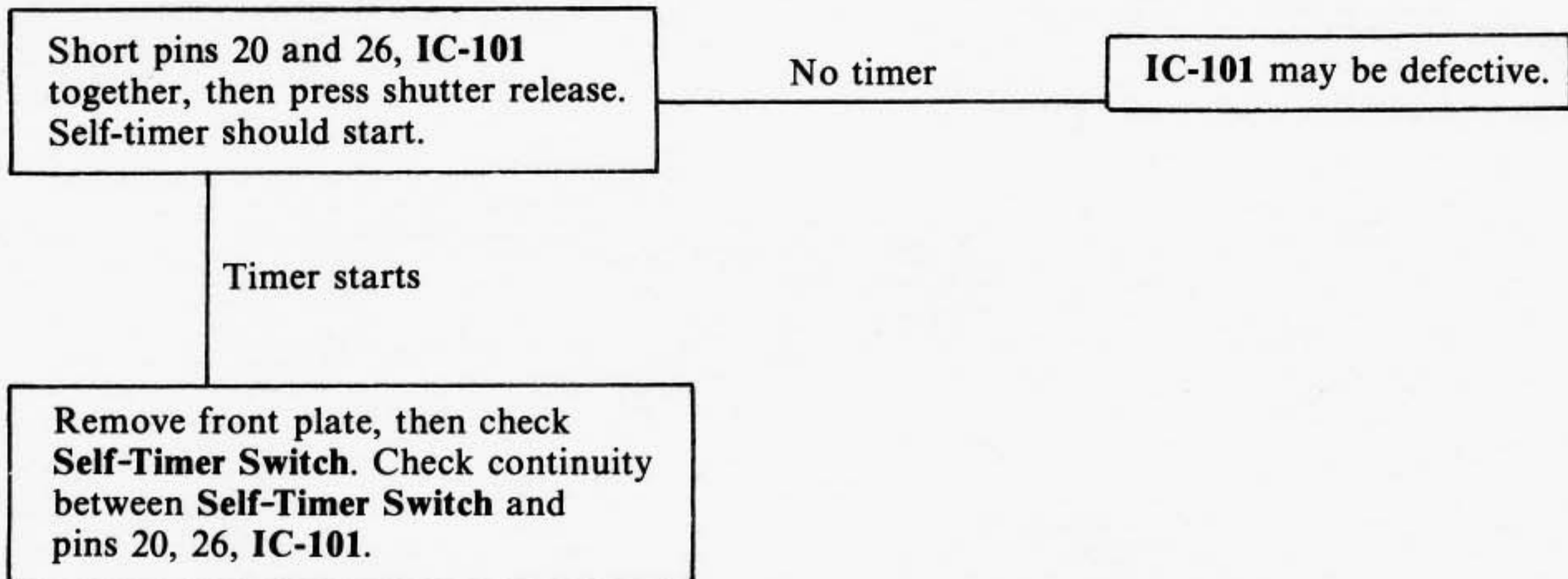

A. External Observations:

No Self-Timer function.
LCD normal.
Shutter functions normal.



B. External Observations:

LED or Piezo Buzzer not working.
Self timer function is normal.

1. For LED, apply B- to pin 41, IC-102 through 1000 ohm probe. If LED flashes, IC-102 may be defective. If no LED, check:
B- to LED
(Black wire from TP-1.) Also, Q-401 and LED.
2. For Piezo Buzzer, check output at pin 52, IC-102. Use scope.    No signal, IC-102 is defective. If signal is present, check connections to Timer Board and Buzzer Switch.

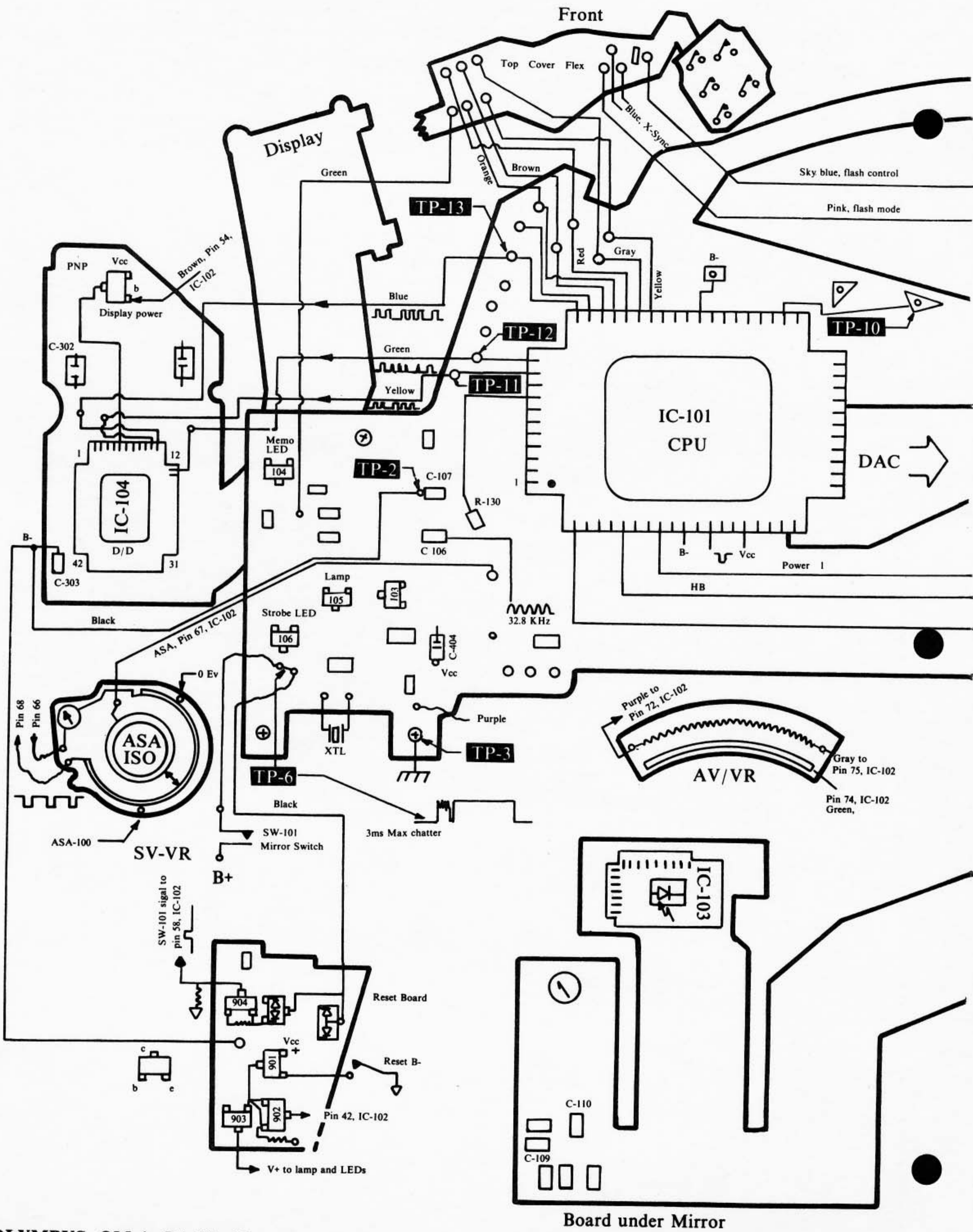

OLYMPUS OM-4

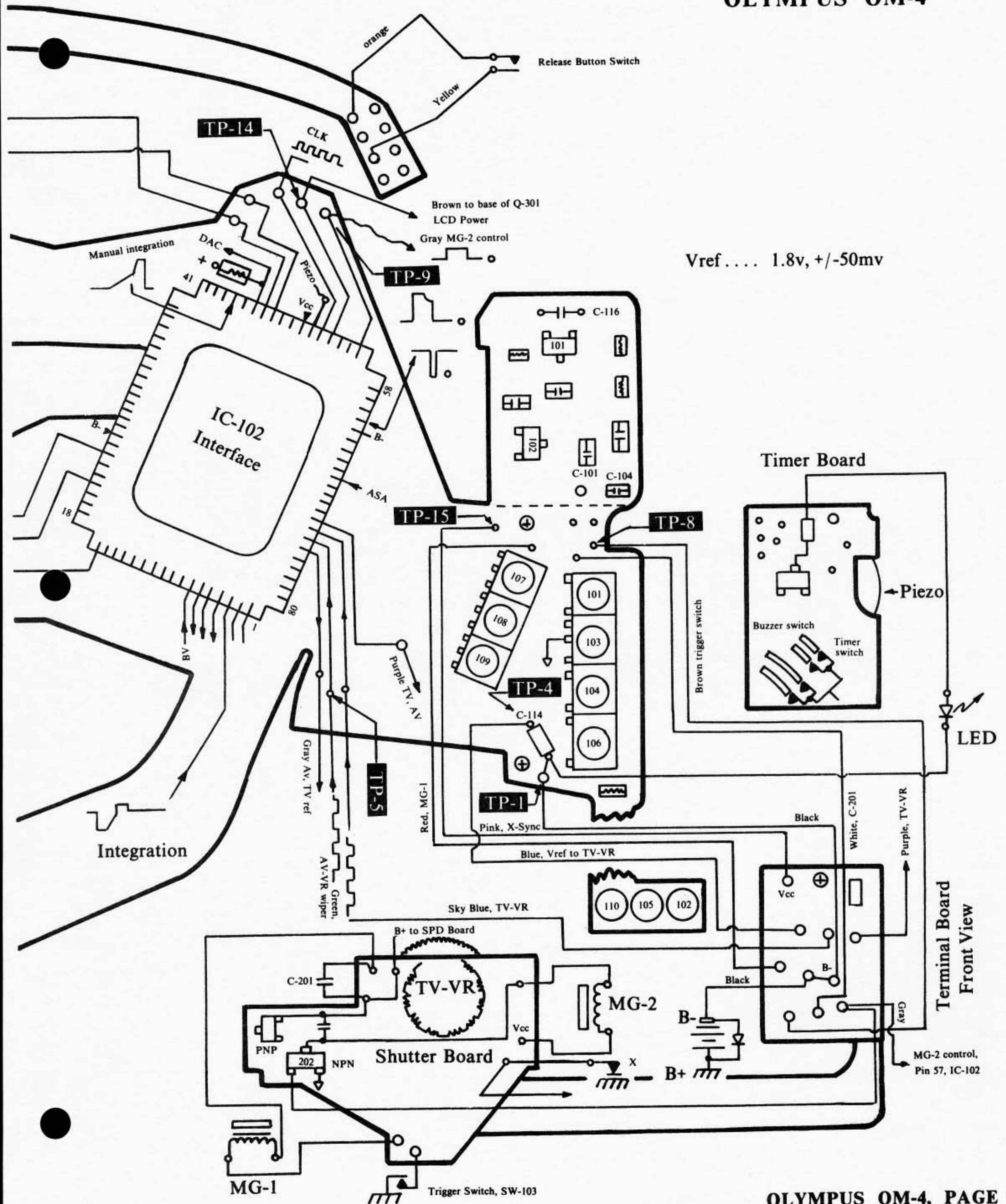

VI. List of Commonly Used Parts

Description _____	Number
Wind lever cap	CE594000
Wind lever screw	CE422000
Wind lever	ZC454200
Shoe	CE5637800
Shoe Spring	CE569500
Shoe base	ZJ177900
Rewind crank	ZJ178400
Rewind knob	CE565500
Crank pin	CA873000
Rewind Spring	CZ511400
ASA dial cover	CE568200
ASA dial	ZC453700
Top cover	ZC453300
Left front leather	CE558300
Right front leather	CE558400
Battery cover	ZC481200
Bottom cover	ZC454100
Tripod socket	CE552700
Film door	ZC453600
Bayonet ring	CE573400
Speed dial	CE572900
Speed dial follower	CE573000

Description _____	Number
AV-VR wiper ring	ZJ177500
AV-VR	CE564000
ASA wiper	ZJ178300
Exposure comp. wiper	ZJ178200
ASA-VR	CE594300
Mode switch wiper	ZJ178100
Rewind shaft	CE565200
Mirror box set lever	ZC452800
Winder contact set	ZC453900
Battery box	CE555500
Screen	CB158700
Main circuit board	ZC458600
Reset board	ZC454500
TV-VR wiper	ZC453100
Shutter Board	ZC454400
LCD display flex	ZC451400
Rear eye-lens	ZJ177800
Forward eye-lens	ZJ177700
Eye-lens frame	CE545200
Eye-lens cover glass	LC420400
MG-2	ZJ175600

©1985 C & C Associates
300 Highfall Ave., Greencastle, IN 46135

All rights reserved. No part of this publication may be reproduced, by any means, electronic, mechanical, photocopying, recording or otherwise, without the prior written consent of the publisher. While every precaution has been taken in the preparation of this manual, the publisher assumes no responsibility for any errors or omissions. Neither is any liability assumed for damages resulting from the use of the information contained herein. C & C Associates reserves the right to make changes or improvements in this manual at any time without notice.

WARNING

Copying, duplicating, selling or otherwise distributing this product is a violation of the law. Willful violations of the Copyright Law of the United States can result in civil damages of up to \$50,000 in addition to actual damages, plus criminal penalties of up to one year imprisonment and/or a \$10,000 fine.