

EXPLODED PARTS DIAGRAM

MODEL	FIG.
X-100 /D-540ZOOM/C-310ZOOM	1/3
OLYMPUS CORPORATION	

Ver.1
2004.03

A

B

C

D

1

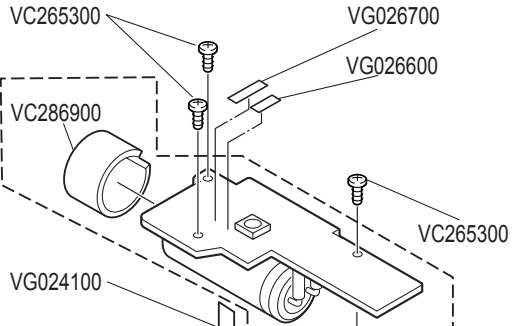

2

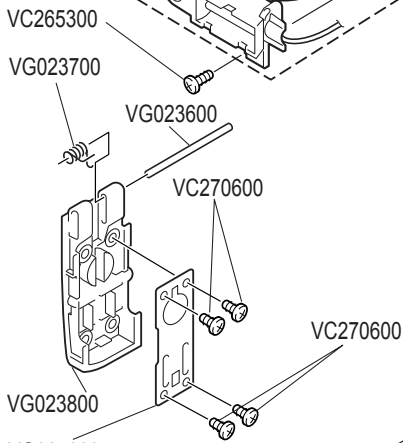

3

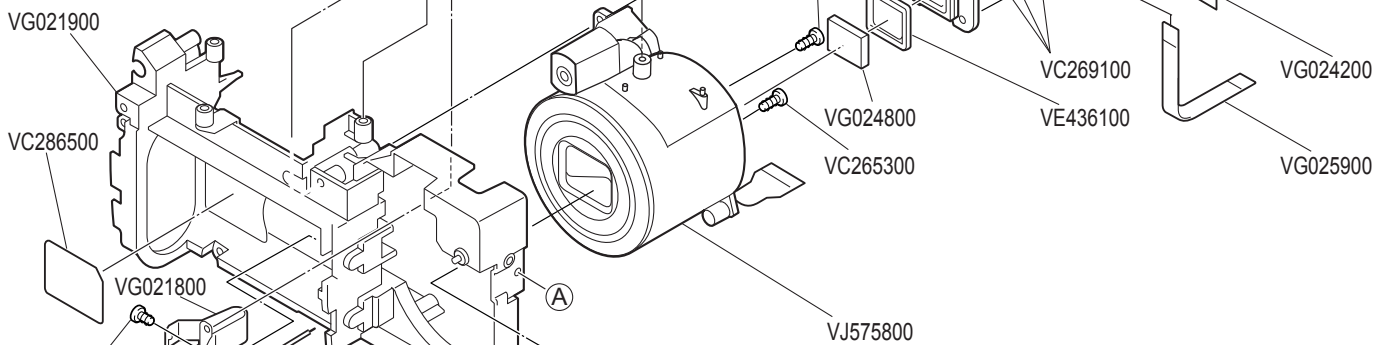

4

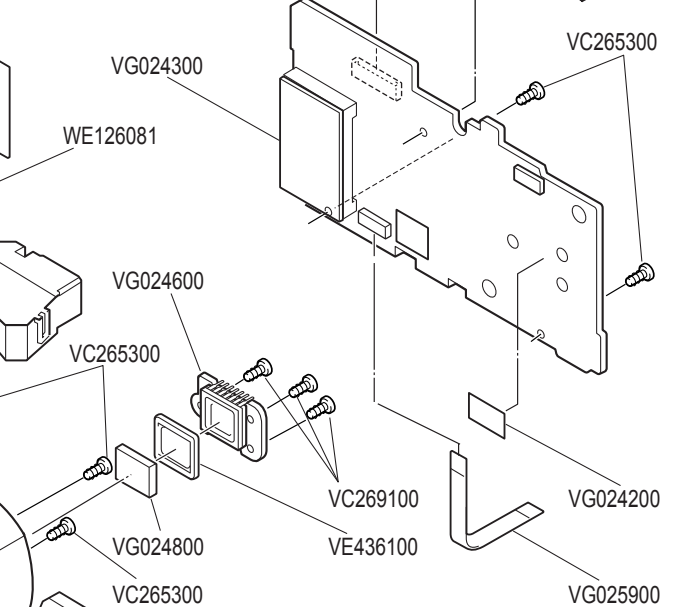
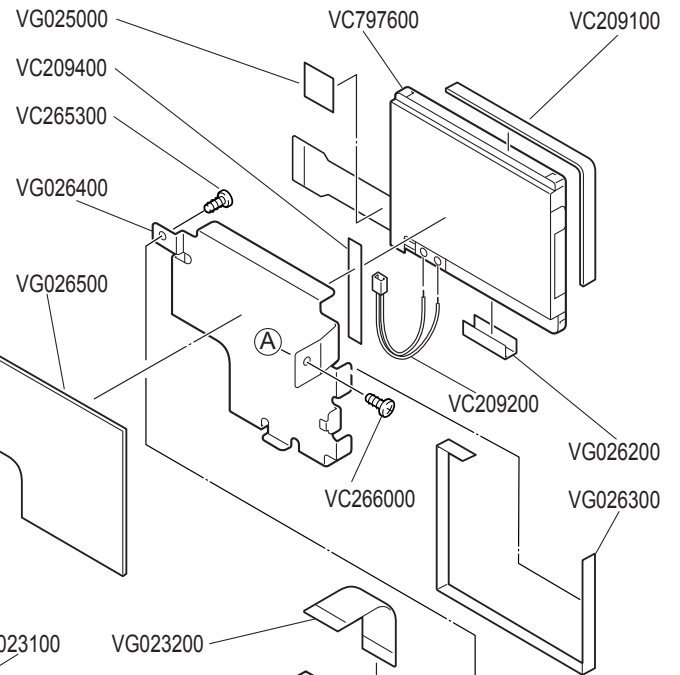
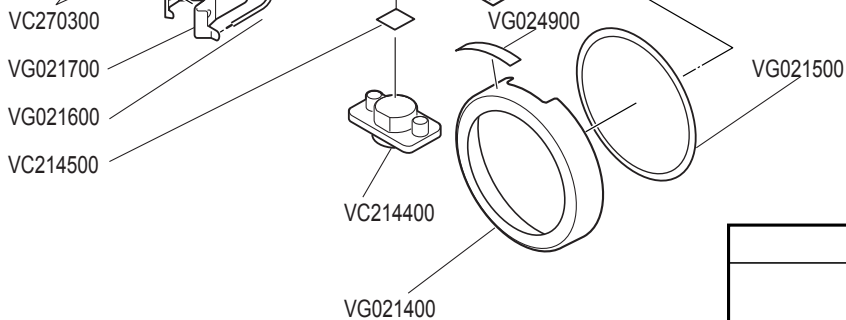

EXPLODED PARTS DIAGRAM

MODEL	FIG.
X-100/D-540ZOOM/C-310ZOOM	2/3
OLYMPUS CORPORATION	

Ver.1
 2004.03

A

B

C

D

1

2

3

4

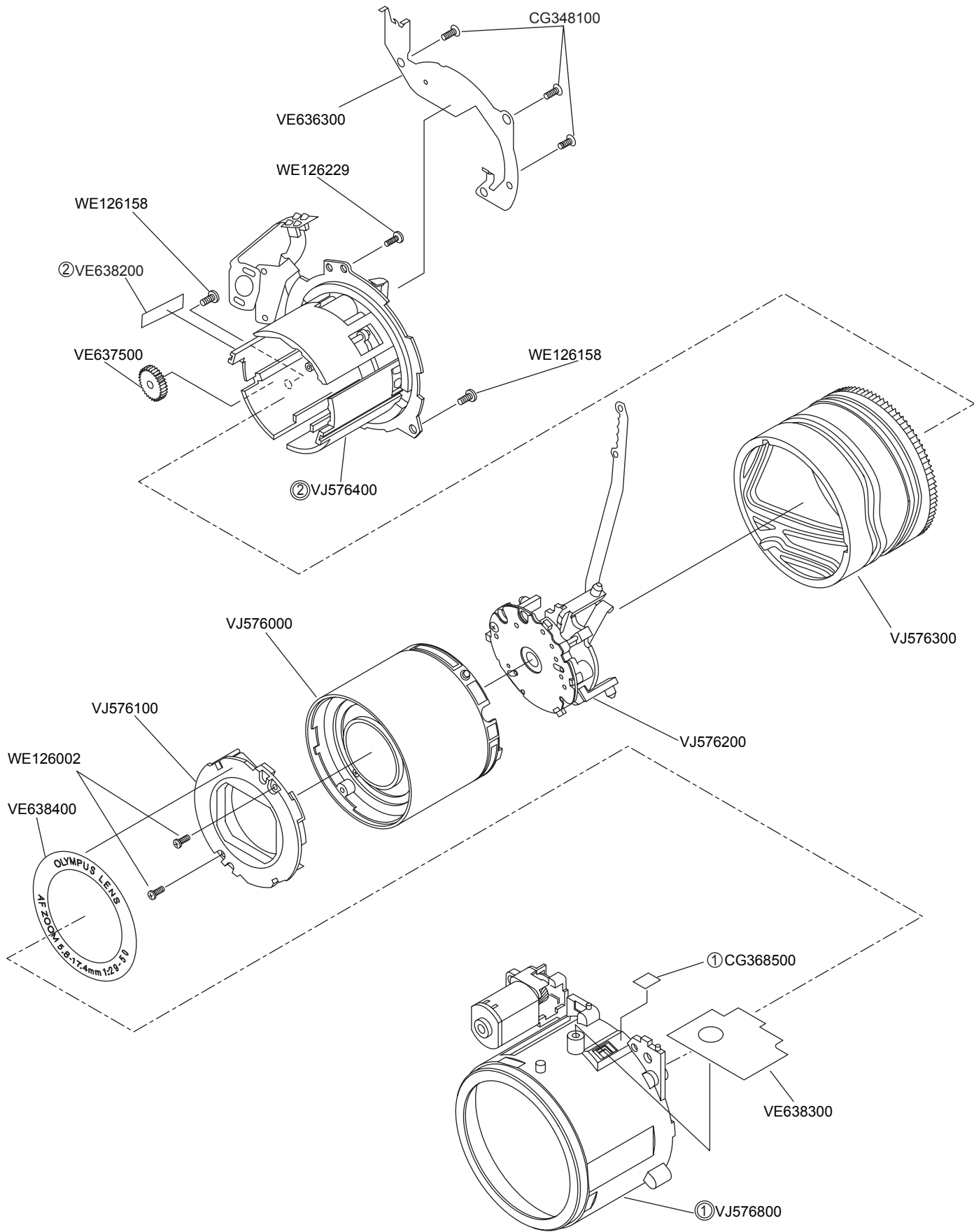

EXPLODED PARTS DIAGRAM

MODEL	FIG.
X-100 /D-540ZOOM/C-310ZOOM	3/3
OLYMPUS CORPORATION	

Ver.1
2004.03

REF NO	PARTS NO	DESCRIPTION	REMARKS	NOTE
	CG348100	SCREW THB1630	3-C1	NEW
	CG368500	RC Tape	3-D3	NEW
	VC209100	SPACER L-LCD	2-D1	
	VC209200	ASSY,WIRE LCD-BL(SR)	2-D2	
	VC209400	ADHESIVE MONITOR A	2-C1	
	VC214400	STAND	2-B4	
	VC214500	ADHESIVE STAND	2-A4	
	VC265300	SCR S-TPG PAN PCS 1.7X4	1-B1,D1,etc	
	VC266000	SCR S-TPG PAN PCS 1.7X3.5	1-B3,C4,etc	
	VC266000	SCR S-TPG PAN PCS 1.7X3.5	2-D2	
	VC269100	SCR S-TPG PAN PCS 1.6X3.5	2-D3	
	VC270300	SCREW 1.7X2.5	2-A4	
	VC270600	SPECIAL SCREW-1.7X2.5	2-A2,B3	
	VC271400	SCR S-TPG PAN PCS 1.7X3	1-A3	
	VC286500	LABEL BATTERY	2-A3	
	VC286900	SPACER MAIN CON	2-A1	
F5005	VC796600	FUSE 32V 6A	CP-1	
F5001	VC796700	FUSE 32V 2A	CP-1	
F5002	VC796700	FUSE 32V 2A	CP-1	
F5003	VC796700	FUSE 32V 2A	CP-1	
F5004	VC796700	FUSE 32V 2A	CP-1	
	VC797600	LCD	2-D1	
S5301	VC866100	SWITCH,PUSH 1P-2TX1	ST-1	
JK501	VC866700	SOCKET,DC	CP-1	
CN110	VC885400	SOCKET,USB	CP-1	
S3002	VC892600	SWITCH,DETECTOR 1P-1T	CP-1	
	VE436100	SPACER	2-D3	
	VE636300	LDPI Holder	3-B1	NEW
	VE637500	Z Gear 5	3-A1	NEW
	VE638200	S FPC Tape 2	3-A1	NEW
	VE638300	PR Tape	3-D4	NEW
	VE638400	1ZCoverRing	3-A3	NEW
	VG019500	CABINET FRONT [X-100]	1-B4	NEW
	VG019600	DEC WINDOW FLASH	1-C3	NEW
	VG019700	BUTTON SHUTTER	1-A3	NEW
	VG019800	SHAFT CARD	1-B1	NEW
	VG019900	HOLDER SHAFT	1-B2	NEW
	VG020000	CABINET FRONT [C-310Z]	1-B4	NEW
	VG020100	CABINET FRONT [D-540Z]	1-B4	NEW
	VG020200	SPACER STROBO	1-C3	NEW
	VG020300	SPRING COMP POWER	1-C2	NEW
	VG020400	LABEL CAUTION [X-100]	1-C1	NEW
	VG020500	SLIDE POWER	1-C2	NEW
	VG020600	SPACER MONITOR	1-C2	NEW
	VG020700	COMPL,CABI BACK [D-540Z,C-310Z]	1-B1	NEW
	VG020800	COMPL,CABI BACK [X-100]	1-B1	NEW
	VG020900	ADHESIVE COVER FRONT	1-A4	NEW
	VG021000	ADHESIVE DEC WINDOW B	1-B3	NEW
	VG021100	EARTH MODE	1-B2	NEW
	VG021200	BUTTON LOCK POWER	1-C2	NEW
	VG021300	SPRING SHUTTER	1-A3	NEW
	VG021400	DEC RING	2-B4	NEW
	VG021500	ADHESIVE DEC RING	2-C4	NEW

PARTS LIST

X-100 / D-540ZOOM / C-310ZOOM

REF NO	PARTS NO	DESCRIPTION	REMARKS	NOTE
	VG021600	ASSY,WIRE BATTERY	2-A4	NEW
	VG021700	TERMINAL BATTERY B	2-A4	NEW
	VG021800	TERMINAL BATTERY A	2-A4	NEW
	VG021900	HOLDER CHASSIS	2-A3	NEW
	VG022000	ASSY,WIRE BAT +	2-B2	NEW
	VG022100	COVER CARD	1-B1	NEW
	VG022200	DEC EYE	1-D1	NEW
	VG022300	COVER USB	1-B1	NEW
	VG022400	CABINET BACK	1-D2	NEW
	VG022500	KNOB POWER	1-D1	NEW
	VG022600	KNOB ZOOM	1-A3	NEW
	VG022700	COVER JACK	1-D4	NEW
	VG022800	ADHESIVE DEC WINDOW	1-B3	NEW
	VG022900	LABEL CAUTION [D-540Z),C-310Z]	1-C1	NEW
	VG023000	SHIELD TAPE F	1-A2	NEW
	VG023100	SPACER FUSE	2-C2	NEW
	VG023200	FLEXIBLE PWB CP1&ST1	2-C2	NEW
	VG023300	BUTTON MODE	1-B2	NEW
	VG023400	COMPL PWB,ST-1	2-B2	NEW
	VG023500	SPACER A	1-D2	NEW
	VG023600	SHAFT COVER BATT	2-A2	NEW
	VG023700	SPRING COVER BATT	2-A2	NEW
	VG023800	COVER BATTERY	2-A3	NEW
	VG023900	ASSY,FLASH	2-A2	NEW
	VG024000	TERMINAL COVER BATT	2-A3	NEW
	VG024100	SPACER FLASH-SX775/JO	2-A2	NEW
	VG024200	PAD(L=7)	2-D3	NEW
	VG024300	COMPL PWB,CP-1	2-C2	NEW
	VG024400	SPACER FLASH LEAD	1-C3	NEW
	VG024500	SHAFT STRAP	1-C3	NEW
	VG024600	ASSY,UNIT,CCD	2-C3	NEW
	VG024700	BUTTON ZOOM	1-B3	NEW
	VG024800	OPTICAL FILTER	2-C3	NEW
	VG024900	SPACER C	2-B4	NEW
	VG025000	SPACER LCD FLEX	2-C1	NEW
	VG025100	COMPL,CABI FRONT [C-310Z]	1-A4	NEW
	VG025200	SHIELD TAPE B	1-B2	NEW
	VG025300	COMPL,CABI FRONT[D-540Z]	1-A4	NEW
	VG025400	COMPL,CABI FRONT [X-100]	1-A4	NEW
S6001	VG025500	SWITCH,PUSH 1P-1T	TB-1	NEW
S6002	VG025500	SWITCH,PUSH 1P-1T	TB-1	NEW
S6003	VG025500	SWITCH,PUSH 1P-1T	TB-1	NEW
S6004	VG025500	SWITCH,PUSH 1P-1T	TB-1	NEW
S6005	VG025500	SWITCH,PUSH 1P-1T	TB-1	NEW
S6006	VG025500	SWITCH,PUSH 1P-1T	TB-1	NEW
S3001	VG025600	SWITCH,SLIDE 1P-3T	CP-1	NEW
	VG025700	COMPL PWB,TB-1	1-A2	NEW
	VG025800	SPACER STROBO C	1-D2	NEW
	VG025900	FLEXIBLE FLAT CABLE	2-D3	NEW
	VG026000	COVER FRONT	1-B4	NEW
	VG026100	SPACER STROBO B	1-D2	NEW
	VG026200	SPACER LCD LIGHT B	2-D2	NEW
	VG026300	SPACER LCD LIGHT A	2-D2	NEW

PARTS LIST

X-100 / D-540ZOOM / C-310ZOOM

REF NO	PARTS NO	DESCRIPTION	REMARKS	NOTE
	VG026400	HOLDER MONITOR	2-C1	NEW
	VG026500	SPACER HL MONITOR	2-C1	NEW
	VG026600	SHIELD TAPE E	2-B1	NEW
	VG026700	SPACER B	2-B1	NEW
	VJ575800	LENS,ASSY	2-C4	NEW
	VJ576000	1Z Frame-ASSY	3-B2	NEW
	VJ576100	BARRIER-ASSY	3-A3	NEW
	VJ576200	2G Frame-ASSY	3-D3	NEW
	VJ576300	CamBarrel-ASSY	3-D2	NEW
	VJ576400	C HOLDER-ASSY1	3-B2	NEW
	VJ576800	BaseFrame-ASSY	3-D4	NEW
	VJ588100	FINDER,ASSY	2-C3	NEW
	VT472600	Rated Label Gi(C-310Z)MADE IN INDONESIA		NEW
	VT785500	Rated Label J(X-100) MADE IN JAPAN		NEW
	VT785600	Rated Label U(D-540Z) MADE IN JAPAN		NEW
	VT785700	Rated Label EG(C-310Z) MADE IN JAPAN		NEW
	VT785800	Rated Label Jc(X-100) MADE IN CHINA		NEW
	VT785900	Rated Label Uc(D-540Z) MADE IN CHINA		NEW
	VT786000	Rated Label Ec(C-310Z) MADE IN CHINA		NEW
	VT786100	Rated Label Gc(C-310Z)		NEW
	VT786200	Rated Label Gc(C-310Z)MADE IN CHINA Sticker		NEW
	VT786300	Rated Label Ji(X-100)MADE IN INDONESIA		NEW
	VT786400	Rated Label Ui(D-540Z)MADE IN INDONESIA		NEW
	VT786500	Rated Label Ei(C-310Z)MADE IN INDONESIA		NEW
	VT786600	Rated Label Gi(C-310Z) Sticker		NEW
	VT786800	Rated Label CC(C-310Z)		NEW
	WE126002	PUTB1.4X3.5SN	3-A3	
	WE126081	PUTB1.6×4SN	2-C2	
	WE126158	PUTB 1.4-135SN	3-B2,C2	NEW
	WE126229	PUTB 1.6-235N	3-B2	